

**THIRD  
EDITION**

*Union Special*  
INDUSTRIAL SEWING EQUIPMENT

**CATALOG NO. 139M**

---

**STYLES**

<b>39800CA</b>	<b>39800CY</b>
<b>39800CB</b>	<b>39800VCP</b>
<b>39800CP</b>	<b>39800VCQ</b>
<b>39800CQ</b>	<b>39800VCX</b>
<b>39800CX</b>	<b>39800VCY</b>

---

**SMALL FRAME HIGH SPEED  
FOUR AND FIVE THREAD SAFETY STITCH  
VERTICAL NEEDLE MACHINES**

C a t a l o g N o. 1 3 9 M

I N S T R U C T I O N S

F O R

A D J U S T I N G A N D O P E R A T I N G

L I S T O F P A R T S

C L A S S 3 9 8 0 0

S t y l e s

3 9 8 0 0 C A	3 9 8 0 0 C Y
3 9 8 0 0 C B	3 9 8 0 0 V C P
3 9 8 0 0 C P	3 9 8 0 0 V C Q
3 9 8 0 0 C Q	3 9 8 0 0 V C X
3 9 8 0 0 C X	3 9 8 0 0 V C Y

T h i r d E d i t i o n

© 1 9 7 4 a n d 1 9 7 9

By

U n i o n S p e c i a l C o r p o r a t i o n  
R i g h t s R e s e r v e d i n A l l C o u n t r i e s

***UNION SPECIAL CORPORATION***

INDUSTRIAL SEWING MACHINES

**CHICAGO**

P r i n t e d i n U . S . A .

November, 1979

## IDENTIFICATION OF MACHINES

Each UNION SPECIAL machine is identified by a Style number which is stamped into the name plate on the machine. Style numbers are classified as Standard and Special. Standard Style numbers have one or more letters suffixed but never contain the letter "Z". Example: "Style 39800 CA". Special Style numbers contain the letter "Z". When only minor changes are made in a standard machine, a "Z" is suffixed to the Standard Style number. Example: "Style 39800 CAZ".

Styles of machines similar in construction are grouped under a class number which differs from the style number in that it contains no letters. Example: "Class 39800".

The distance between the rows of stitches or between the needles is represented by a gauge number measured in 1/64ths of an inch (.40 mm), going from left to right. The width of overedge is represented by a fraction. Collectively, the gauge number and the width of overedge represent the machine gauge. Example: "5-1/8". Thus, 5-1/8 gauge represents a distance of 5/64 inch (1.98 mm) between the left needle (401 stitch) and the right needle (503 or 504 stitch) and the 1/8 inch (3.18 mm) represents the width of overedge to the right of the right hand needle.

## APPLICATION OF CATALOG

This catalog applies specifically to the Standard Styles of machines as listed herein. It can also be applied with discretion to some Special Styles of machines in this class. Reference to direction, such as right, left, front, back, etc., are given from the operator's position while seated at the machine. Operating direction of handwheel is away from operator.

## STYLES OF MACHINES

Vertical Needle, Small Frame, High Speed, Two Straight Needles, Left Needle in Front, Differential Feed, Light, Medium and Heavy Duty Machines, Trimming Mechanism with Spring Pressed Lower Knife, Automatic Lubricating System, Improved Air Cooling System.

39800 CA Two loopers, one spreader, four thread dual stitch; 401 double locked stitch on left needle and 503 two thread overedge stitch on right rear needle. Light to medium duty machine for simultaneously seaming and overedging on sport and dress shirts, ladies' blouses, street and house dresses, coat and jacket linings, pillow cases and similar operations on light to medium weight durable press or conventional materials. Seam specification, (401-503) 515-SSa-2; standard gauge and seam widths are 5-1/8 (1.98-3.18 mm) and 12-3/16 (4.76-4.76 mm); stitch range, 7 to 12 per inch, cam adjusted main and differential feeds. Maximum recommended speed 7000 R.P.M.

39800 CB Same as Style 39800 CA, except three loopers, five thread dual stitch; 401 double locked stitch on left needle and 504 three thread overedge stitch on right rear needle. Seam specification (401-504) 516-SSa-2. Standard gauge and seam widths are 5-1/8 (1.98-3.18 mm) and 12-3/16 (4.76-4.76 mm).

39800 CP Same as Style 39800 CA, except medium to heavy duty for operations on slacks, jackets, sport shirts, street and house dresses, coat linings, shoulder pads and similar operations on medium to medium heavy weight materials. Standard gauge and seam widths are 5-1/8 (1.98-3.18 mm), 8-3/16 (3.18-4.76 mm) and 12-3/16 (4.76-4.76 mm). Maximum recommended speed 6500 R.P.M.

## STYLES OF MACHINES (Continued)

- 39800 CQ Same as Style 39800 CP, except three loopers, five thread dual stitch; 401 double locked stitch on left needle and 504 three thread overedge stitch on right rear needle. Seam specification (401-504) 516-SSa-2.
- 39800 CX Same as Style 39800 CP, except equipped with tractor type presser foot and associated sewing parts. Standard gauge and seam widths are 8-3/16 (3.18-4.76 mm) and 12-3/16 (4.76-4.76 mm).
- 39800 CY Same as Style 39800 CQ, except equipped with tractor type presser foot and associated sewing parts. Standard gauge and seam widths are 8-3/16 (3.18-4.76 mm) and 12-3/16 (4.76-4.76 mm).
- 39800 VCP Same as Style 39800 CP, except equipped with "AIR-KLIPP" vacuum chain cutter. Standard gauge and seam width 12-3/16 (4.76-4.76 mm) only.
- 39800 VCQ Same as Style 39800 CQ, except equipped with "AIR-KLIPP" vacuum chain cutter. Standard gauge and seam width 12-3/16 (4.76-4.76 mm) only.
- 39800 VCX Same as Style 39800 CX, except equipped with "AIR-KLIPP" vacuum chain cutter. Standard gauge and seam width 12-3/16 (4.76-4.76 mm) only.
- 39800 VCY Same as Style 39800 CY, except equipped with "AIR-KLIPP" vacuum chain cutter. Standard gauge and seam width 12-3/16 (4.76-4.76 mm) only.

### SPEED RECOMMENDATION

These machines have been tested in their complete stitch range at their maximum rated speeds. Varied field conditions, severity and cleanliness of the sewing operation may necessitate operating at a lower speed. When operating from 50-100% machine running cycle and a longer than recommended stitch length, it may be necessary to reduce the machine's speed by 10-15%.

The 39800 is a precision manufactured and tested sewing machine. To obtain maximum performance, the machine should be operated at 1000 R.P.M. below maximum recommended speed for the first 20 days of field operation. This will minimize readjustment of precision mechanisms.

### OILING

CAUTION! Oil was drained from machine when shipped, so reservoir must be filled before beginning to operate. Oil capacity of Class 39800 is six ounces (180 ml). A straight mineral oil of a Saybolt viscosity of 90 to 125 seconds at 100° Fahrenheit should be used.

Machine is filled with oil at spring cap under the top cover. On later model machines, an oil filler fitting has been provided in the back side of the bed casting, located directly in front of the lower overedge looper thread tension post nut. Oil level is checked at sight gauge on front of machine. Red bulb on oil level indicator should show between gauge lines when machine is stationary.

Machine is automatically lubricated. No oiling is necessary, other than keeping main reservoir filled. Check oil daily before the morning start; add oil as required.

To maintain maximum recommended speed and serviceability of this equipment when operating continuously, the oil must be changed at least every six months. In no case should oil remain in the machine for more than one year.

•"AIR KLIPP" is a registered trademark of Union Special Corporation.

## OILING (Continued)

The oil drain plug screw is located at back of machine near bottom edge of base. It is a magnetic screw designed to accumulate possible foreign materials which may have entered the crank case. It should be removed and cleaned periodically.

## NEEDLES

Each UNION SPECIAL needle has both a type and size number. The type number denotes the kind of shank, point, length, groove, finish and other details. The size number, stamped on the needle shank, denotes largest diameter of blade, measured in thousandths of an inch, midway between shank and eye. Collectively, type number and size number represent the complete symbol which is given on the label of all needles packaged and sold by Union Special.

Two straight needles of the same length are used in these machines. The recommended needles are Type 120 GS, Size 080/032 for Styles 39800 CA, CB (5-1/8 gauge); Size 090/036 for Styles 39800 CA, CB (12-3/16 gauge), 39800 CP, CQ (5-1/8 gauge) and all 8-3/16 gauge machines. Type 120 GAS, Size 125/049 is recommended for all 12-3/16 gauge machines, except Styles 39800 CA and CB. Type 120 GS is a round shank, round point, set point, extra short, double groove, struck groove, ball eye, spotted, rounded scarf, with a 3/64 inch (1.19 mm) radius at scarf, chromium plated needle and is available in sizes 075/029, 080/032, 090/036, 100/040, 110/044, 125/049, and 140/054. Type 120 GAS is the same as Type 120 GS, except it has a modified point; available in sizes 110/044, 125/049 and 140/054.

Other useable needles are Type 120 GFS which is the same as Type 120 GS, except it has a reduced eye and groove; available in sizes 110/044 and 125/049.

Type 120 GHS is the same as Type 120 GS, except it has a thin ball point, available in same sizes.

Type 120 GKS is the same as Type 120 GS, except it has an oversize ball eye; available in sizes 075/029, 080/032, 090/036, 100/040 and 110/044.

To have needle orders promptly and accurately filled, an empty package, a sample needle, or type and size number should be forwarded. Use description on label. A complete order would read: "1000 Needles, Type 120 GS, Size 080/032".

Selection of proper needle size is determined by size of thread used. Thread should pass freely through needle eye in order to produce a good stitch formation.

Success in the operation of UNION SPECIAL machines can be secured only by use of needles packaged under our brand name, *Union Special*<sup>®</sup>, which is backed by a reputation for producing highest quality needles in materials and workmanship for more than three-quarters of a century.

## CHANGING NEEDLES

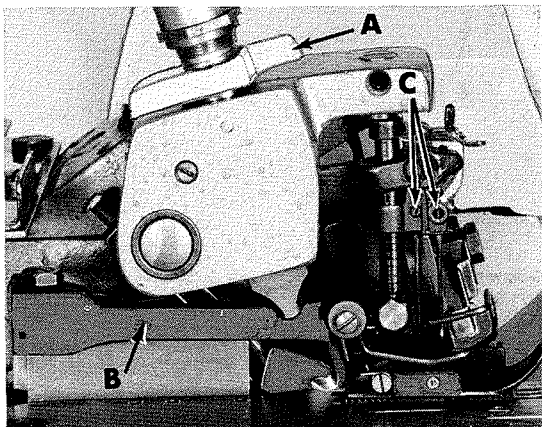

Fig. 1

Release pressure on presser foot by turning presser foot release lever (A, Fig. 1) and swing presser arm (B) out of position. With needles at high position, loosen screws (C) in needle head and withdraw needles.

To replace needles, insert same into needle head as far as they will go, assuring that the scarf of the needles are to the rear, tighten screws (C, Fig. 1) securely. Return presser arm (B) to position; lock presser foot release lever (A).



## THREADING

Thread from thread stand (C, Fig. 2 or 2A) is threaded through the upper holes of tension thread guide (D) from front to back and then through the lower holes from back to front: NOTE: Thread No. 2 (401 looper - blue color code) is threaded through the upper hole of tension thread guide (D) from back to front and down through tension post thread bar eyelet (E). All other threads continue between the tension discs (L), through tension post slot (M) in tension post (J) and on through its proper hole in front thread guide (P).

It will simplify the threading of these machines to follow the recommended sequence as designated by the numbers assigned to each thread, starting with thread No. 1, then No. 2, etc. The various eyelets and guides on the machine for each thread have been color coded to further aid the threading process.

Thus, the threading sequence for Styles 39800 CA, CP, CX, VCP, VCX, (503 stitch) is as follows; Thread No. 1, lower looper thread - golden beige color code; thread No. 2, 401 looper thread - blue color code; thread No. 3, overedge needle thread - green color code; thread No. 4, 401 needle thread - red color code.

The threading sequence for Styles 39800 CB, CQ, CY, VCQ, VCY, (504 stitch) is as follows; Thread No. 1, 504 lower looper thread - golden beige color code; thread No. 2, 401 looper thread - blue color code; thread No. 3, 504 upper looper thread - black color code; thread No. 4, overedge needle thread - green color code; thread No. 5, 401 needle thread - red color code.

Before beginning to thread, swing cloth plate open, turn handwheel in operating direction until the needles (R, Fig. 2 or 2A) are at their highest position, release pressure on presser foot by turning presser foot release lever (A), and swing presser arm (B) out of position.

### THREADING LOWER LOOPER (Golden Beige Color Code)

Turn handwheel until the point of lower looper (S) is all the way to the right. Use threading wire #39899 A (Fig. 2 or 2A) by inserting into the left end of tube (T) and push through same; through the inside of take-up wires (U) passing over and/or in front of cast-off blade (V) and through long tube (W) until the threading wire protrudes out of same in front of the front thread guide (P). Hook lower looper thread (No. 1) into the threading wire and pull back until the thread comes out of the left end of tube (T). Turn handwheel until the lower looper (S) is at its extreme left position; then thread lower looper through its left eye, entering from the rear and through the right eye, entering from the front.

### THREADING 401 LOOPER (Blue Color Code)

Double end of 401 looper thread (No. 2) and feed same from right to left through thread tube (X) or use threading wire #39899 A in reverse manner; thread through tension thread eyelet (Y) from back to front passing between tension discs around the bottom of tension post, then continuing forward to the cast-off support plate (Z). Thread through adjustable eyelets (AA) from left to right passing under cast-off wire (AB) and over the take-up, under thread guide wires (AC), through pigtail eyelet (AD) from left to right and up through eyelet on shank of looper (AE). Insert doubled end of thread into right eye of looper (AE) from right to left, pushing through approximately an inch or so of thread. Holding tweezers in left hand, insert doubled end of thread into left eye, from front to back, using about 3/16 inch (4.76 mm) projection of thread from point of tweezers. DO NOT THREAD LOOPER WITH NEEDLE LOOP AROUND LOOPER. REMOVE LOOP, OTHERWISE MACHINE WILL NOT SEW.

- F** Tension Nut
- G** Tension Spring Ferrule
- H** Tension Spring
- J** Tension Post
- L** Tension Discs
- M** Tension Post Slot
- N** Tension Disc Felt

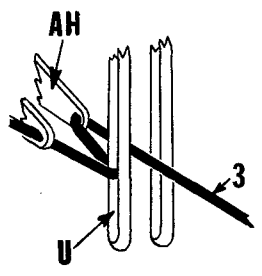

NOTE: Thread #3 for Upper Looper should go thru ONLY the LEFT Take-Up Wire (U)

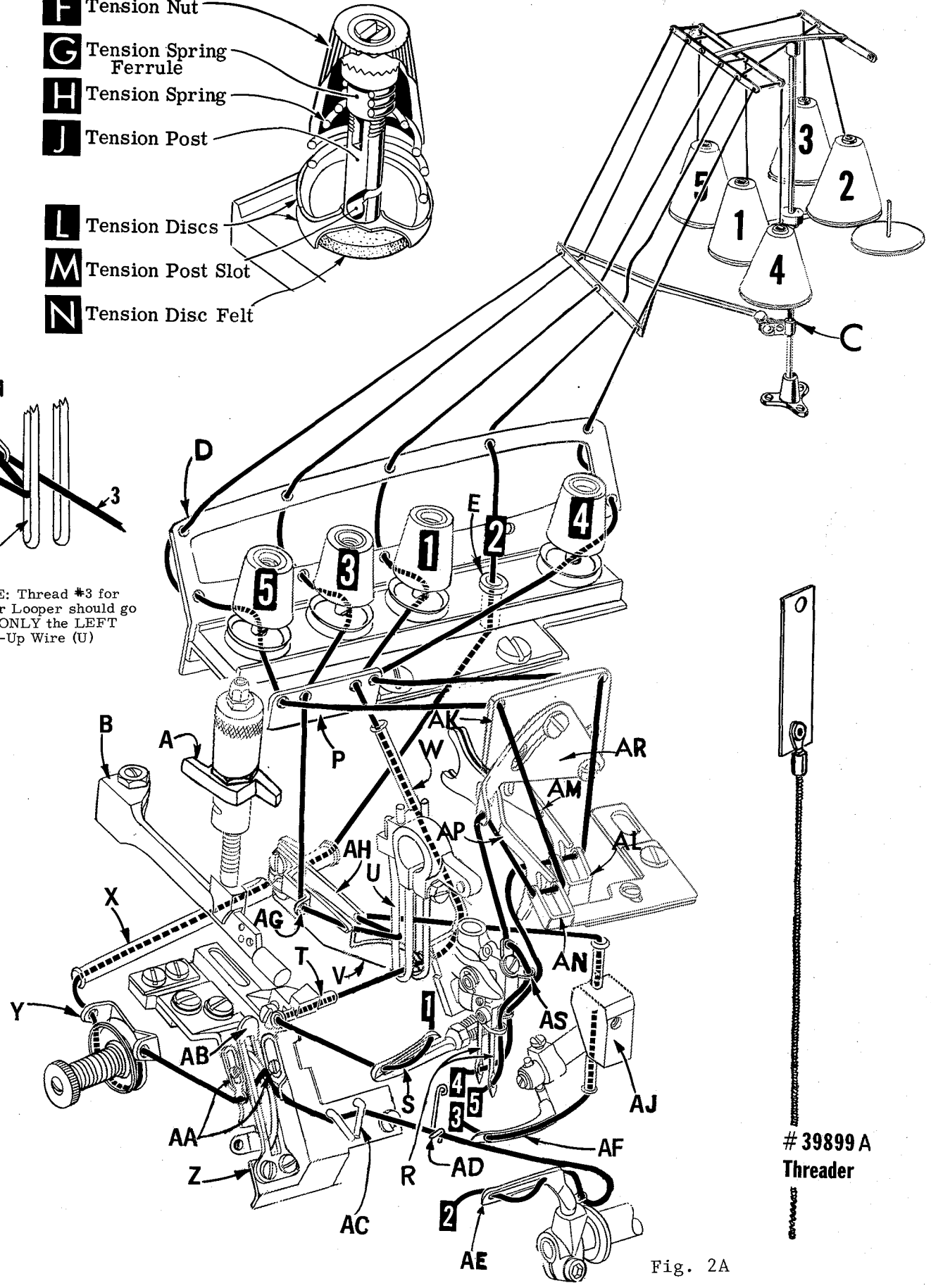

# 39899 A  
Threader

Fig. 2A



### THREAD UPPER LOOPER (Black Color Code)

Turn handwheel until point of upper looper (AF) is all the way left. Double end of upper looper thread (No. 3 on Styles 39800 CB, CQ, CY, VCQ, VCY) and lead the thread through the auxiliary looper thread eyelet (AG) from back to front and then through both eyes of the upper looper thread eyelet (AH) from left to right; passing through the inside of the LEFT take-up wire (U) and in front of the RIGHT take-wire.

After pulling up the upper looper thread tube assembly (AJ), lead thread down through tube assembly and pull thread out bottom of tube. Push tube down and insert the thread through the eye of the upper looper (AF) from front to back.

### THREADING OVEREDGE NEEDLE (Green Color Code)

Pass the overedge needle thread (No. 3 on Styles 39800 CA, CP, CX, VCP, VCX; No. 4 on Styles 39800 CB, CQ, CY, VCQ, VCY) through the right eye of needle thread frame eyelet (AK) from back to front, through both eyes of needle thread pull-off eyelet (AL) from right to left, passing in front of needle thread cam pull-off (AM) and down through the right eyelet on needle head, finally through the eye of the right needle (R) from front to back.

### THREADING 401 NEEDLE (Red Color Code)

Pass the 401 needle thread (No. 4 on Styles 39800 CA, CP, CX, VCP, VCX; No. 5 on Styles 39800 CB, CQ, CY, VCQ, VCY) through the left eye of needle thread frame eyelet (AK) from back to front, down through both eyes of needle thread pull-off eyelet (AN) from right to left, passing in front of needle thread cam pull-off, (AP) up through needle thread adjustable eyelet (AR) from right to left, and down through both holes in top eyelet (AS) on needle head from back to front, down through lower eyelet on left side of needle head, then finally through the eye of the left needle (R) from front to back.

### THREAD TENSION

The amount of tension on the needle and looper threads is regulated by the knurled tension nuts (F, Fig 2 or 2A). Tension on the threads should be only enough to secure proper stitch formation. Using a postal scale, the measurements are taken with the needles at the top of their stroke and pulled in the direction as indicated. As a start, the approximate tensions should be as follows:

401 needle thread; 2 to 2 1/2 oz. (56.70 to 70.87 gr) straight out of lower eyelet on left side of needle head.

Overedge needle thread; 1 1/2 to 2 oz. (42.52 to 56.70 gr) straight out of lower eyelet on right side of needle head.

Lower looper thread; 1 to 1 1/2 oz. (28.35 to 42.52 gr) straight out of left end of thread tube (T. Fig. 2 or 2A).

Upper looper thread; 1 to 1 1/2 oz. (28.35 to 42.52 gr) straight out bottom of thread tube assembly (AJ. Fig. 2A).

401 looper thread; 1 to 1 1/2 oz. (28.35 to 42.52 gr) straight out of eye at point of looper (AE, Fig. 2 or 2A)

Further refinement of thread tension adjustments will be required to suit a particular seam, thread or material and is discussed at the conclusion of the adjusting instructions.

## PRESSER FOOT PRESSURE

Sufficient pressure to feed work uniformly should be maintained. Should it be necessary to increase or decrease amount of pressure on presser foot, loosen lock nut (A, Fig. 3) and turn the adjusting screw (B). Adjusting screw has a right hand thread so tightening increases the pressure, loosening decreases pressure. When pressure adjusting screw (B) has been properly set, tighten lock nut (A) against adjusting screw (B). With presser foot resting on the throat plate, position locking nut (C) so that its under surface is approximately 1/32 to 1/16 inch (.79 to 1.59 mm) from the top surface of adjusting screw (B). Set the cap (D) against the locking nut (C).

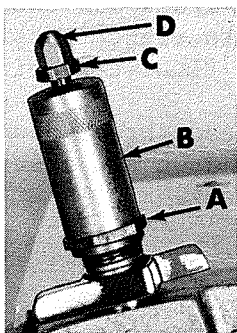

Fig. 3

## FEED ECCENTRICS

Feed eccentrics used in these machines have been selected to produce approximately 10 stitches per inch (2.5 mm per stitch) on Styles 39800 CA, CB (all gauges), 39800 CP, CQ, (5 1/8 gauge); and 8 stitches per inch (3.2 mm per stitch) on Styles 39800 CP, CQ, CX, CY, VCP, VCQ, VCX, VCY (8-3/16 or 12-3/16 gauge) machines. It will be noted that part number 39540 B-9 or 39540 B-10 are the main and differential feed eccentrics for machines producing 10 stitches per inch, while 39540 B-8 are the main and differential feed eccentrics for machines producing 8 stitches per inch.

Minor numbers of the part symbol indicate approximately the number of stitches obtainable when using that eccentric. Unless otherwise specified, machine will be shipped with eccentrics as stated in previous paragraph.

Generally speaking, differential (right hand) feed eccentric determines the number of stitches produced; the main (left hand) feed eccentric is selected in relation to the degree and direction of stretch of material being sewn, or the type of operation.

The following stitch number feed eccentrics are available under No. 39540 B; 4, 5, 6, 7, 8, 9, 10, 11, 12, 13, 14. Only two eccentrics are supplied with each machine. Additional eccentrics may be ordered separately. To order an eccentric, use No. 39540 B with a minor number suffixed to indicate number of stitches desired. Example: "39540 B-10".

## ASSEMBLING AND ADJUSTING SEWING PARTS

Before assembling and adjusting sewing parts, remove cloth plate, fabric guard chip guard, upper knife assembly, lower knife holder assembly, then follow this suggested sequence.

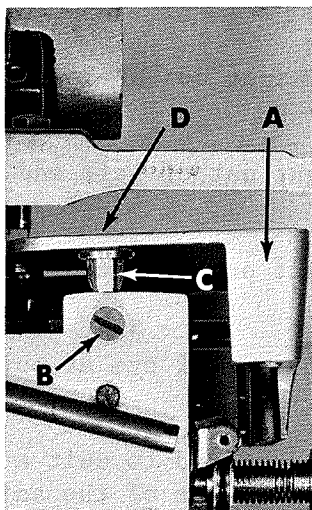

Fig. 4

## CLOTH PLATE REMOVAL AND ASSEMBLY

**CAUTION!** When removing the cloth plate (A, Fig. 4) loosen the cloth plate stud locking screw (B) and lift up cloth plate with the cloth plate stud (C) and cloth plate screw (D) assembled.

In assembly, the cloth plate screw and the cloth plate stud are tightened to the point of removing all play and yet turn in cloth plate. The cloth plate is then assembled to the machine with the flat and "V" slot of the cloth plate stud (C) towards the rear. Stud locking screw (B) is tightened securely which collapses the body of the stud to the screw (D) so that only the cloth plate will turn when opening or closing.

## SETTING THE NEEDLES

With throat plate assembled in position, the needles should center in the throat plate needle slots (left to right). The needle head (A, Figs. 5 and 6) can be repositioned by loosening set screws (B, Fig. 5) and binder screw (B, Fig. 6) in needle drive lever (C, Figs. 5 and 6); then; simultaneously turning needle head guide bar (D) which is an eccentric and sliding the needle drive lever (C) to the left or right on needle rock shaft as required to alleviate bind. When proper left to right needle position is obtained, tighten set screws (B, Fig. 5) securely and tighten screw (B, Fig. 6) lightly.

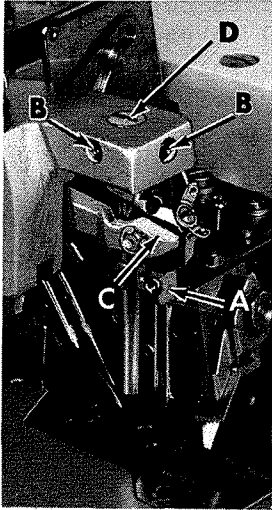

Fig. 5

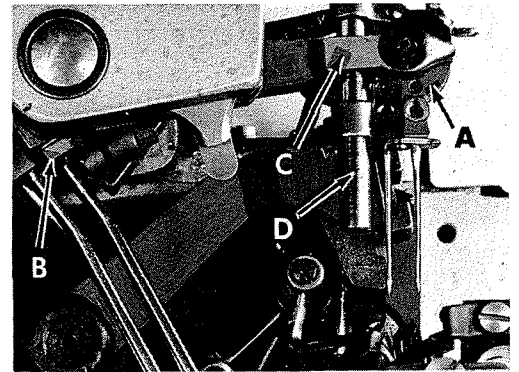

Fig. 6

Needle Drive lever (C, Fig. 5 and 6) must also be positioned to set height of needles above throat plate which should be 7/16 inch (11.11 mm) on Styles 39800 CA and CB; 17/32 inch (13.49 mm) on Styles 39800 CP, CQ, CX, CY, VCP, VCQ, VCX, VCY with needles at top of stroke (W, Fig. 7). Tap the needle drive lever (C, Figs. 5 and 6) lightly up or down to obtain desired needle height. Needle gauge No. 21227 DD can be used by placing it on top of the throat plate and bringing the needle head bottom to rest on top of the gauge. This will have the needles at the bottom of their stroke. Note that the gauge has separate heights, one for high, the other for low capacity machines. Tighten screw (B, Fig. 6) securely.

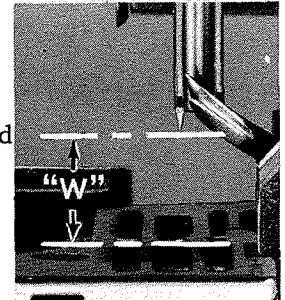

Fig. 7

### SETTING OVEREDGE LOWER LOOPER

Insert the lower looper (A, Fig. 8) into bar (B). With lower looper at the left end of its stroke, set looper point 3/32 inch (2.38 mm) from centerline of right needle (C). Set looper point into needle scarf to touch but not deflect approximately .001 inch (.025 mm) clearance. Adjustment can be made by rocking the looper forward or backward around its shank. Recheck specified lower looper gauge setting and tighten nut (D, Fig. 8). Check for .025 inch (.635 mm) minimum looper clearance under throat plate stitch tongue (see sketch). Add .009 inch (.229 mm) shims No. 39880 H under throat plate support bracket if needed, but not to exceed two shims. For proper setting, looper point should be at or slightly below center of needle scarf. Needle height may have to be changed if more than one shim is used.

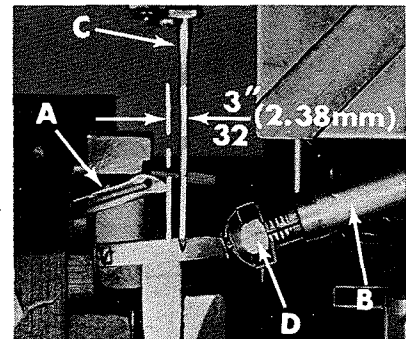
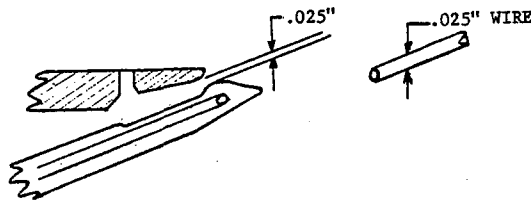

Fig. 8



## SETTING OVEREDGE REAR NEEDLE GUARD

When overedge lower looper point is at needle scarf, set overedge rear needle guard (A, Fig. 9) so that it touches but does not deflect the needle, .000 to .004 inch (.000 to .102 mm) clearance. Check to ensure that needle guard does not interfere with lower looper or movement of the lower knife holder. Screw (B) is used to set the rear needle guard. The needle thread is to be free to pass through the needle eye without being pinched by the needle guard with the needle down.

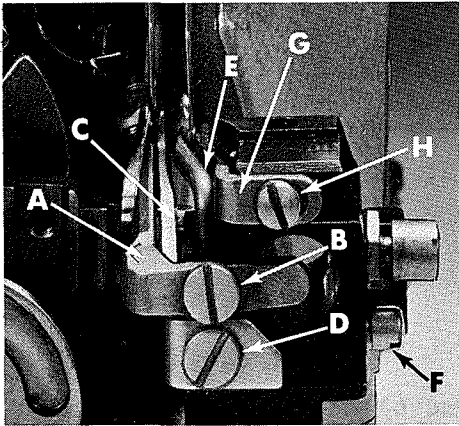

Fig. 9

interference between needle guards and differential feed dog.

## SETTING OVEREDGE FRONT NEEDLE GUARD

With needle at bottom position, set front overedge needle guard (C, Fig. 9) to touch but not deflect needle, .000 to .004 inch (.000 to .102 mm) clearance. Guard should not pinch thread in needle eye. Screw (D) is used to set front needle guard. After making adjustment, make sure there is no inter-

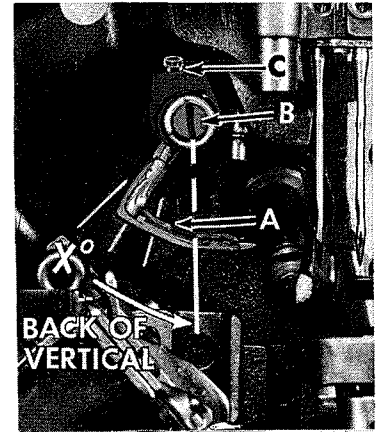

Fig. 10

## SETTING OVEREDGE UPPER LOOPER OR SPREADER

NOTE: When using upper looper, use looper No. 39808 A for needle sizes 075/029 through 100/040. Use looper No. 39808 C for needle sizes 110/044 through 140/054.

Insert upper looper or spreader (A, Fig. 10) in its holder. Screw (B) holds the looper or spreader in its holder and permits looper or spreader to be pushed in or out, or turned around its shank. Screw (C) in the collar holds the holder in the shaft and allows the holder to be rotated or adjusted laterally.

NOTE: Specific settings for the various machine Styles, are as follows:

Machine Styles	(Fig. 10) "X" Approximate Degrees Shank Back of Vertical	(Fig. 11) "Y" Spreader's Lower Point to Left of Centerline of Right Needle	(Fig. 11) "Y" Looper Point to Left of Center- line of Right Needle	(Fig. 11) "Z" Height Above Throat Plate
39800 CA	15°	5/32 inch (3.97 mm)	-----	19/32 inch (15.08 mm)
39800 CB	45°	-----	11/64 inch (4.37 mm)	9/16 inch (14.29 mm)
39800 CP, CX VCP, VCX	15°	5/32 inch (3.97 mm)	-----	21/32 inch (16.67 mm)
39800 CQ, CY VCQ, VCY	45°	-----	5/32 inch (3.97 mm)	21/32 inch (16.67 mm)

## SETTING OVEREDGE UPPER LOOPER OR SPREADER (Continued)

When looper or spreader is at the right end of its stroke, the holder should be set to position the looper or spreader shank approximately "X" degrees back of vertical and flush with the top of holder (Fig. 10) on all Styles except 39800 CA, CB; and approximately 1/16 inch (1.59 mm) above the holder on Styles 39800 CA, CB. On later machines with the new looper/spreader holder (See Fig. 10 A), settings are the same for "X", "Y", and "Z" except for location of shank with respect to top of holder. This setting should be approximately 1/32 inch (.79 mm) above holder on all Styles except 39800 CA, CB, and approximately 3/32 inch (2.38 mm) above the top of holder on Styles 39800 CA, CB. These settings may vary depending on needle size. NOTE: Lines in bed casting represent 15, 30 and 45 degrees back of vertical. CAREFULLY set looper or spreader point to cross lower looper to the left of lower looper eye with approximately .002 inch (.051 mm) clearance. At extreme left end of travel the looper point or the lower point of the spreader should be set "Y" dimension to the left of the centerline of the right needle and "Z" dimension above throat plate (Fig. 11).

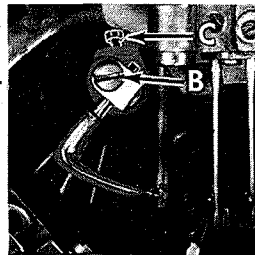

Fig. 10A

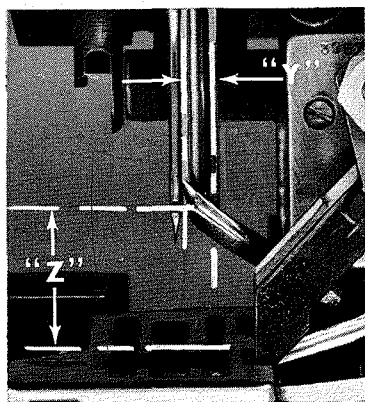

Fig. 11

Now check relationship between looper or spreader and needle to ensure no deflection. If needle rubs back of either, pull looper or spreader out of its holder slightly and rotate the holder forward a short distance. These same adjustments, in opposite movement, will reduce the clearance between looper or spreader and needle. Reset to lower looper and recheck crossover setting.

NOTE: on larger size needles (125/049 and 140/054), some needle

deflection may result, but should not exceed .002 inch (.051 mm). Fig. 12

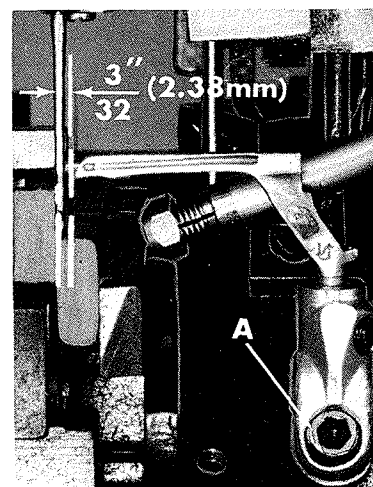

Fig. 12

## SETTING 401 STITCH LOOPER

Insert 401 stitch looper into looper holder and press down until the butt end of the shank strikes the looper shaft. Looper will be at correct height. Tighten the looper clamp screw while working the looper blade to and fro to secure accurate seating of clamp screw against flat on shank.

With looper at the right end of its stroke, set looper 3/32 inch (2.38 mm) from centerline of left needle (Fig. 12), using looper gauge No. 21225-3/32. Loosen looper holder binder screw (A, Fig. 12) to position the looper.

Turn the handwheel to bring the looper point up to the needle and set the looper point to touch the needle without deflecting, approximately .001 inch (.025 mm) clearance, viewing the machine from the left end (Fig. 13). Retighten looper holder binder screw. Check for .025 inch (.635 mm) minimum 401 looper clearance under throat plate.

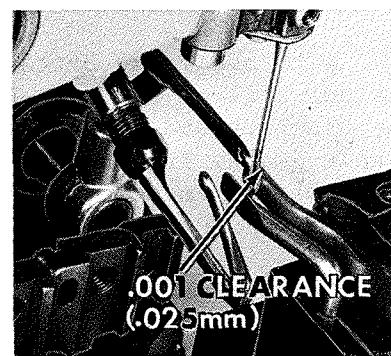

Fig. 13

## SETTING 401 STITCH LOOPER (Continued)

These machines are fitted with an adjustable 401 looper avoid link to accommodate extreme needle sizes from 075/029 to 140/054. Machines shipped from the factory will, have the setting for the sizes as listed under the "NEEDLES" paragraph, unless otherwise specified. Should adjustment become necessary, drain oil from the machine and remove bottom cover. Loosen nut (A, Fig. 14) and rotate eccentric stud (B) to align the letter "S", "M" or "L" which represent small, medium or large looper avoid, respectively, with timing mark in looper avoid link (C) as required. To ensure a uniform setting, position the needle head at the bottom of its stroke before aligning the letter on the eccentric stud with respect to the timing mark in the looper avoid link. Recommended settings for machines using needles sizes:

075/029, 080/032, 090/036 -----	"S"
080/032, 090/036, 100/040 -----	"M"
110/044, 125/049, 140/054 -----	"L"

Tighten nut (A) to 24-25 in lbs.  
(28-29 cm/kg). Replace bottom cover and fill machine to proper oil level.

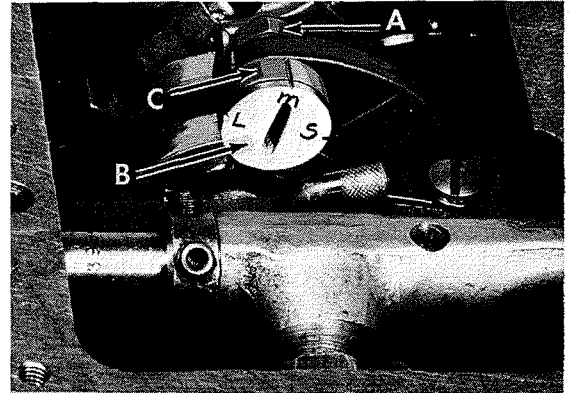

Fig. 14

While hand turning machine through cycle, observe the action of the needle with relation to the looper. As needle rises from the bottom of its stroke, the looper will approach the needle from the right side and pass behind same at top of needle scarf without striking. Further rising of the needle will result in the looper point entering the scarf. Furthermore, since the needle point is coming off the rear guard, the needle will resume its normal position by moving to the rear, resulting in a close relation of the needle and looper, or actual contact, until scarf passes looper. On the down stroke, the needle should pass behind the looper without the point glancing off the guarding surface of the looper.

## SETTING 401 STITCH REAR NEEDLE GUARD

Insert rear needle guard into the hole in the throat plate support bracket. When 401 looper point is at the center of the needle scarf, set 401 rear needle guard (E, Fig. 9) so it touches but does not deflect needle, .000 to .004 inch (.000 to .102 mm) clearance. This guard setting will be approximately 3/16 to 7/32 inch (4.76 to 5.56 mm) below throat plate seat. With needle in down position, guard should not pinch thread in needle eye. Then lock the guard in place with set screw (F).

## SETTING 401 STITCH FRONT NEEDLE GUARD

With needle at bottom position, set front 401 needle guard (G, Fig. 9) to touch but not deflect needle, .000 to .004 inch (.000 to .102 mm) clearance. Guard should not pinch thread in needle eye. Check for clearance between 401 looper and front 401 needle guard. Turn handwheel in operating direction, making complete revolutions to check whether needle is disturbed or pinched. Lock with screw (H).

For convenience, the looper may now be threaded as shown in (Fig. 2 or 2A) and as described under paragraph "To Thread 401 Looper". Replace differential feed dog, throat plate, lower knife holder and reset upper knife. Check cutting action with thread.

## SETTING THE FEED DOGS

Assemble main and differential feed dogs (A, B, Fig. 15).

Feed dogs should be level with the throat plate surface by rotating feed tilting adjusting pin (C). This pin raises or lowers the back end of feed bar. Feed dogs should be level at the time teeth first appear above the throat plate. Screw (D) locks the feed tilting adjusting pin in place. Now set feed dogs at highest point of travel. Main and differential feed dog teeth should be set  $3/64$  inch (1.19 mm) above the throat plate.

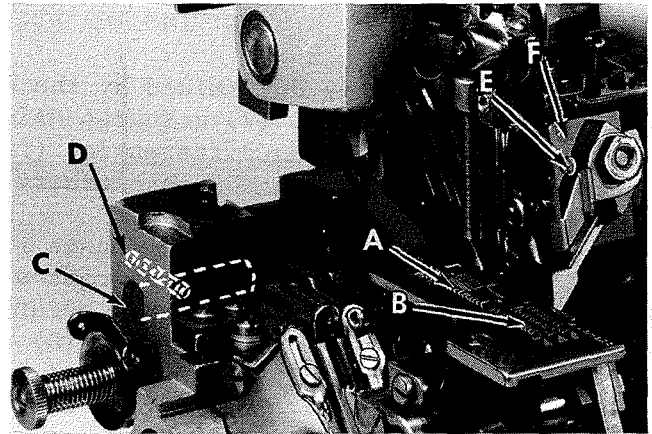

Fig. 15

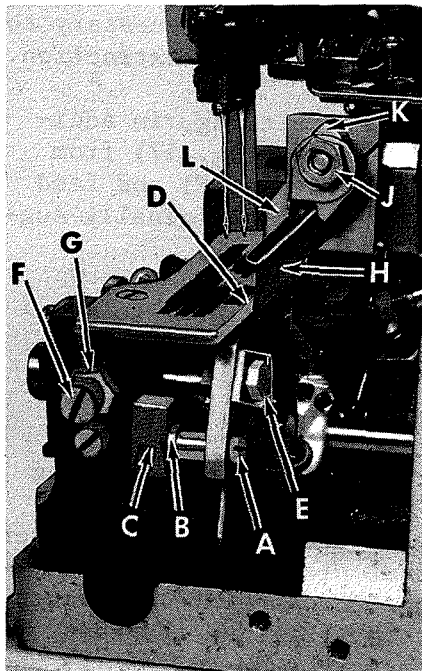

Fig. 16

## SETTING THE LOWER KNIFE

Replace the lower knife holder assembly. In replacing the lower knife holder assembly, tighten screw (A, Fig. 16) so that when the face of the flange on sleeve (B) seats against throat plate mounting bracket (C), a free lateral motion of the lower knife and holder assembly is obtained when the knife is manually pressed at its upper corner. Lower knife (D) should be set with cutting edge flush with top of throat plate. Adjustments are made with hexagonal head screw (E) which holds the lower knife. Lower knife is spring pressed against the upper knife, so no lateral adjustment is necessary when the width of trim is changed.

Lower knife may be secured in any position by tightening screw (F) and locking nut (G) against support bracket. Because screw (F) also serves as latch pin for the cloth plate latch spring, it should always be locked with nut (G) even when screw is not tightened against lower knife holder.

## SETTING THE UPPER KNIFE

Replace the upper knife assembly. Clamp upper knife (H, Fig. 16) in position, setting nut (J) to hold clamp (K) in its most clockwise position against upper knife. At the bottom of its stroke, front cutting edge of upper knife should extend not less than  $1/64$  inch (.40 mm) below cutting edge of lower knife. The chain guard (L) should be set down against the upper knife and slightly back from the cutting edge.

After upper knife has been set for proper width of trim, screw (E, Fig. 15) should be tightened to lock upper knife holding block (F) in place. This will simplify resetting when upper knife is replaced.

## SETTING THE STITCH LENGTH

Length of stitch is determined by the combination of feed eccentrics used. Outer (left) eccentric (A, Fig. 17) actuates main (rear) feed dog, while the inner (right) eccentric (B) actuates the differential (front) feed dog. In assembling feed eccentrics, be sure hubs are facing each other. Be careful not to damage shaft or key.

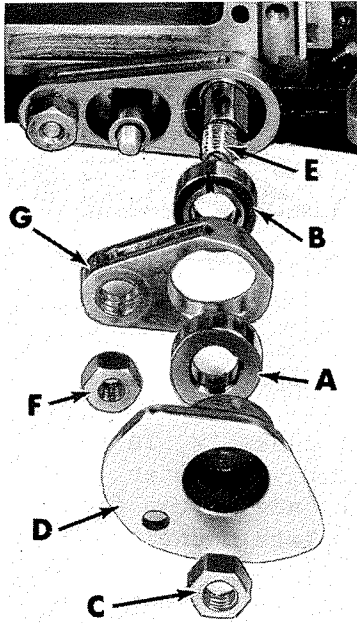

Fig. 17

To change feed eccentrics, remove screws (A, Fig. 18) securing cast-off support end plate (B); remove screws (C) and screw securing the extreme right end of cast-off support plate (D) accessible with chip chute (E) open; turning handwheel to position 401 looper at extreme right, permitting removal of the left main feed thrust bar guide (F) with cast-off support plate (D) assembled. Remove nut (C, Fig. 17) and looper thread take-up (D) from end of shaft (E). Turn handwheel in operating direction until key slot in eccentric is toward front. Using hooked eccentric extractor supplied with machine, reach behind eccentrics and withdraw eccentrics. It may be necessary to move handwheel back and forth slightly during extraction.

If eccentrics are unusually tight fitting, in addition to removing nut (C) and take-up (D, Fig. 17) from shaft (E), it may be helpful to remove nut (F) and feed driving connection (G). Then continue as originally suggested.

NOTE: Before tightening nut (C, Fig. 17) refer to paragraphs under "401 Looper Thread Control Adjustments".

## SETTING THE PRESSER FOOT

Assemble the presser foot to presser arm. With needle in high position, swing presser arm into sewing position and set the presser foot to align needle holes (front and back) and flat on throat plate. The front edge of needle hole in presser foot must be aligned with front edge of needle hole in throat plate. It is also important that the bottom of the presser foot lies flat on the throat plate. If necessary, presser foot can be realigned with throat plate slots by shifting the foot lifter lever shaft (A, Fig. 19). To move the shaft, loosen screws in collar (B) and clamp screw (C) and then shift the foot lifter lever shaft to the left or right as required. Retighten collar screws and clamp screw.

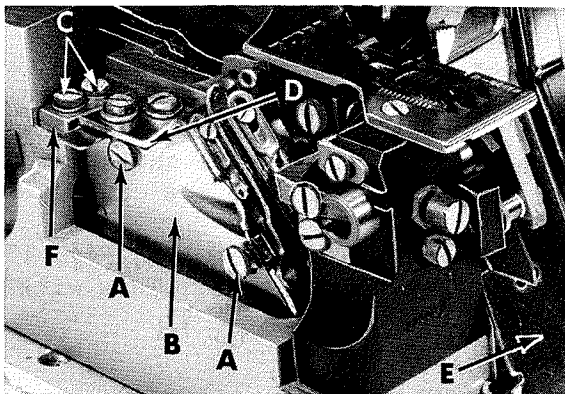

Fig. 18



Fig. 19



## SETTING THE PRESSER FOOT (Continued)

The foot lifter lever arm (D, Fig. 19) and the collar (B) secure the shaft. Be sure the presser arm does not bind and rise when presser foot release lever is unlocked.

Adjust lifter lever stop screw (E, Fig. 19) so that presser foot can be raised no higher than upper looper or spreader will permit; then lock the nut (F). There should be from 1/16 to 1/8 inch (1.59 to 3.18 mm) free motion of foot lifter lever before the presser foot begins to rise. This adjustment should be made with screw (G) and locked with nut (H). Re-assemble the chip guard, fabric guard and cloth plate. To assemble chip guard, turn handwheel until upper knife assembly reaches its highest position.

NOTE: Tractor presser foot to be set with front wall of 401 needle slot in presser foot to be 1/16 inch (1.59 mm) forward from front wall of 401 needle slot in throat plate. Check to make sure 401 and overedge needle does not interfere with presser foot when presser foot is raised to highest position and front portion of foot is tilted down in front.

### 401 LOOPER THREAD CONTROL ADJUSTMENTS

Check alignment of looper thread take-up (A, Fig. 20) in slot of cast-off support plate (B), which should be centered horizontally and vertically. Should adjustment be necessary, loosen screws (C), reposition plate (B) as required while rotating handwheel several revolutions. Tighten screws (C) securely.

With the needle head at the top of its stroke, the long flat of looper thread take-up (A, Fig. 20) should be positioned to begin taking up slack of the looper thread (long flat parallel to cast-off support plate). It may become necessary to slightly advance or retard take-up later, to produce a satisfactory 401 stitch.

The adjustable eyelets (D, Fig. 20) partially determine the amount of looper thread that goes into the stitch. When set at their lowest position, the maximum amount of thread is drawn. Initial setting should be 1/8 inch (3.18 mm) from the highest position. They may be lowered to put more looper thread into the stitch as required.

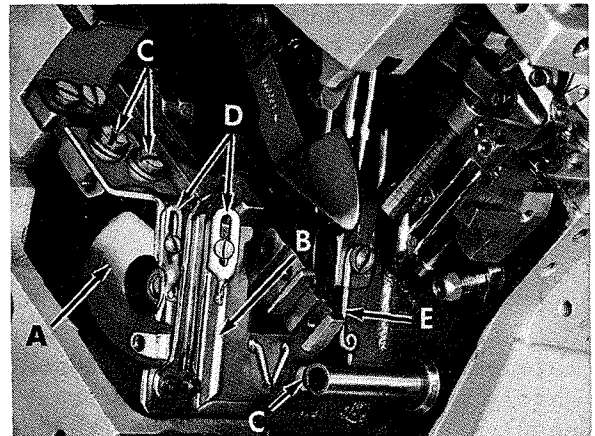

Fig. 20

Set pigtail eyelet (E, Fig. 20) initially at the six o'clock position. Vary this position slightly, if necessary, until the 401 looper thread is taut when the needles reach their highest position.

NOTE: When eccentric cams are changed or looper thread take-up requires adjustment, always torque nut (C, Fig. 17) to 24-25 in. lbs. (28-29 cm/kg).

NOTE: For lighter thread, cast off looper thread 1/32 inch (.79 mm) below throat plate.

### STARTING TO OPERATE

Be sure the machine is threaded according to the threading diagram (Fig. 2 or 2A).

## OVEREDGE LOWER LOOPER THREAD CONTROL

Set thread tube (W, Fig. 2 or 2A) so the opening at its left end aligns with thread tube (T), though later it may be repositioned slightly to suit conditions. With needles at high position, the opening of the lower looper thread take-up wires (U) should be centered between the thread tubes, front to back. Adjustment can be made by loosening screw (A, Fig. 21), reposition take-up wire lever as required and retighten screw. A preliminary setting of the lower looper cast-off blade (V, Fig. 2 or 2A) is to position its curved section to contact thread as soon as the needle head commences its downward stroke and barely touches the thread on its vertical surface located at the heel of the blade as the needle head completes its downward stroke. The cast-off blade can later be raised or lowered to increase or decrease amount of thread required in the system.

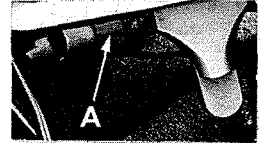

Fig. 21

NOTE: When adjusting cast-off blade and tightening its mounting screw, be sure that the fabric guard rests on top of thread tube (T).

## OVEREDGE NEEDLE THREAD CONTROL

While sewing on material, check needle thread control as follows: Usually all needle thread is drawn on needle down stroke. Needle thread take-up (AM, Fig. 2 or 2A) should be set approximately in the center to upper portion of its slot, though it can be adjusted up or down to suit conditions. With the needle head at lowest position, the finger of the take-up (AM) should be set approximately 1/32 inch (.79 mm) below the thread holes in eyelet (AL) for the 504 stitch. The 503 stitch requires more strike-off and should be set approximately 1/8 to 3/16 inch (3.18 to 4.76 mm) depending on thread, material and stitch length. With needle head at highest position, the curved section of thread take-up (AM) should barely touch the needle thread. Adjust eyelet bracket (AL) forward or rearward to meet these conditions.

## UPPER LOOPER THREAD CONTROL

With needles at high position, set looper thread eyelet (AH, Fig. 2A) approximately horizontal and so positioned, with thread taut through eyelet holes, thread barely contacts inside front wire of the left take-up wire (U). Make sure when needles are at down position, the rear wire of the left take-up wire (U) does not strike the inside of eyelet (AH). Usually all looper thread should be drawn on needle down stroke.

## 401 NEEDLE THREAD CONTROL

Set needle thread adjustable eyelet (AR, Fig. 2 or 2A) so that most of the needle thread is drawn on the down stroke. Eyelet (AS) located at top of needle head should be positioned with the bottom eye in line with the left needle.

## THREAD TENSIONS

With take-ups and eyelets set, as described under thread controls, balance the thread tensions to obtain desired 401 and overedge stitch.

## "AIR-KLIPP" VACUUM CHAIN CUTTER ADJUSTMENTS

The "AIR-KLIPP" chain cutter tube should be assembled as close to the cut-out in the throat plate as possible without touching; .005 inch (.127 mm) to .030 inch (.762 mm) clearance.

## "AIR-KLIPP" VACUUM CHAIN CUTTER ADJUSTMENTS (Continued)

Check that knife pressure is only enough to ensure proper cutting. Set movable knife to trim.

The "AIR-KLIPP" chain cutter should be capable of cutting, NOT TEARING, a single strand of thread when turning machine over by hand.

The cutting edge of the movable knife should extend beyond the cutting edge of the stationary knife a minimum of 1/64 inch (.40 mm) when at extreme right end of stroke.

Care must be taken to provide clearance between movable knife and inner wall of "AIR-KLIPP" chain cutter tube when the movable knife is at the extreme right end of stroke.

Lubricate felt, oil wick and movable knife with a straight mineral oil equivalent to Union Special Specification No. 175.

### SPECIAL ADJUSTMENTS

SKIPPING: If skipping occurs, check and/or adjust the following:

#### (A) Overedge stitch

1. Recheck lower looper to needle setting.
2. Recheck overedge needle guard setting.
3. Recheck upper looper or spreader to lower looper setting.
4. Recheck upper looper or spreader to needle setting.

#### (B) 401 Skitch

1. Recheck 401 looper to 401 needle setting.
2. Recheck 401 needle guard settings.
3. Check 401 looper cast-off cam take-up timing - see note under "401 Looper Thread Control Adjustments".
4. Should 401 chain skipping occur, recheck "Setting The Presser Foot".

## TO REMOVE CRANKSHAFT

Crankshaft can be withdrawn easier if these steps are follow:

1. Drain oil by removing plug screw located on back of machine near bottom edge of base.
2. Remove top and bottom covers of machine.
3. Remove nut (A, Fig. 22) 401 looper thread take-up (B) and eccentrics (C).

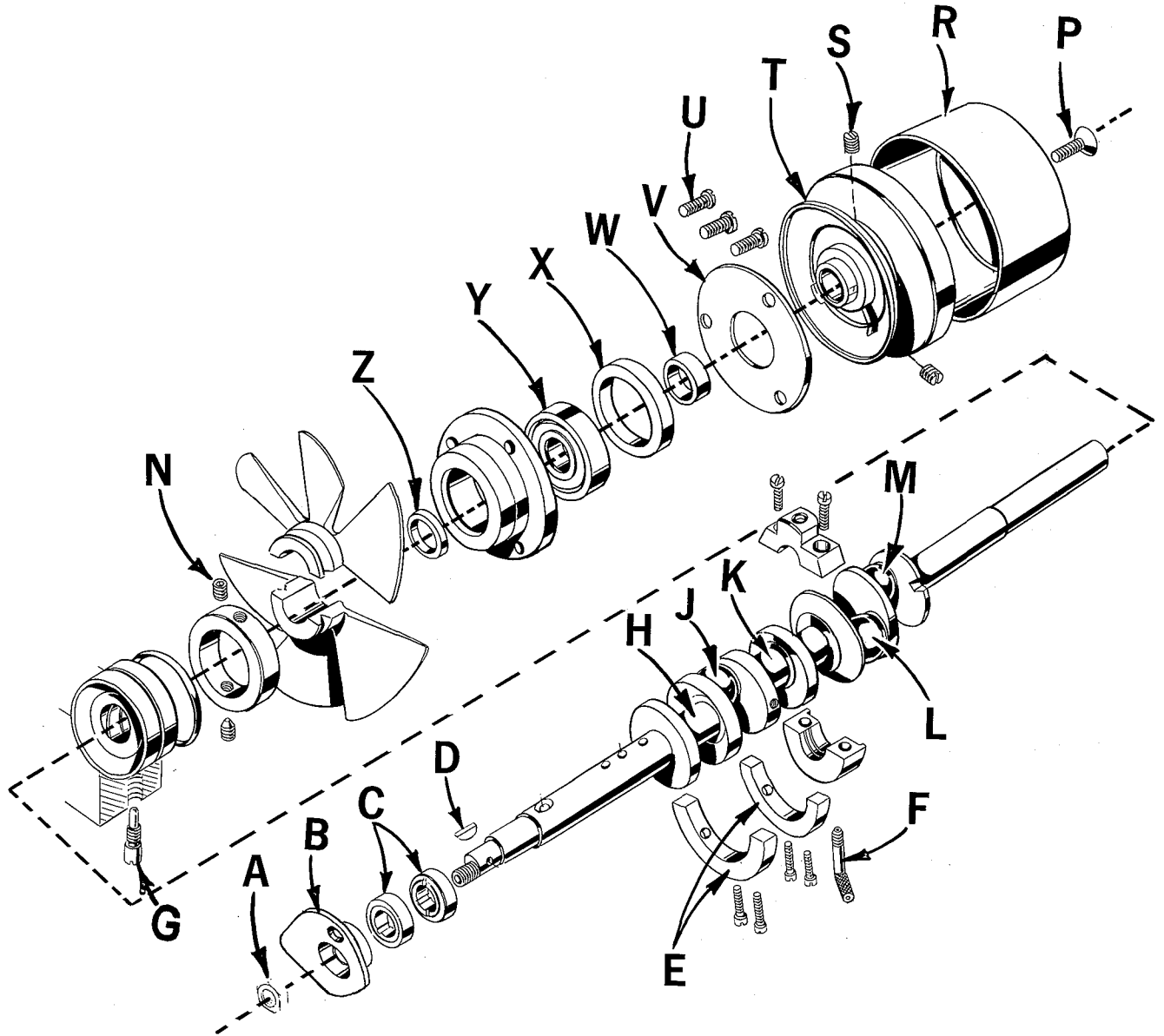

Fig. 22

4. Remove key (D).
5. Remove two counterweights (E). Identify these counterweights so that they will be re-assembled in the proper places.

TO REMOVE CRANKSHAFT (Continued)

6. Remove oil tube (F) which holds crankshaft split bearing and oil pump, and the screw (G) which holds the inner right crankshaft bearing. They are accessible through bottom of bed casting.
7. Remove caps of bearings on crankshaft at points H, J, L and M. When reassembling bearing caps make sure they are in their original position. Trademarks are stamped on both halves of the caps and both trademarks should be on the same side of the bearings. Also, screws should be reassembled in the same holes from which they were removed.
8. Remove 401 looper drive lever shaft.
9. Remove upper looper or spreader drive lever shaft from the rear of machine and lift out the drive lever and connecting rod.
10. Remove upper looper or spreader drive shaft bushing and cam guide.
11. Remove lower looper drive lever shaft from the rear of machine, disconnect connecting link and lift out lower looper drive lever and connecting rod.

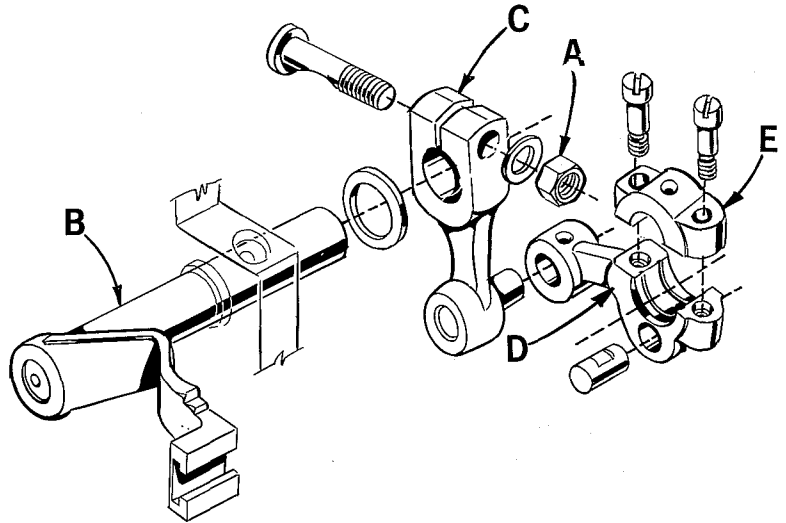

Fig. 23

12. Remove lower looper thread take-up wire and take-up eyelet mounting bracket.
13. Remove throat plate and lower knife support bracket.
14. Loosen clamp nut (A, Fig. 23) which holds the upper knife driving arm (B). Access to clamp nut is through top cover. Draw driving arm to the left until upper knife driving lever (C) and connecting rod (D) drop, allowing removal of bearing cap (E). This is at bearing point (K, Fig. 22) on crankshaft. Observe same precautions when reassembling cap as described in paragraph 7.
15. Loosen two screws (N) in fan collar; remove both halves of cooling fan.
16. Remove screw (P); take off pulley cap (R).
17. Loosen two screws (S): remove pulley (T).
18. Remove three screws (U); take off bearing retaining plate (V): also, spacer collars (W) and (X) may be removed at this time.
19. Crankshaft may now be removed while holding needle lever connecting rod to the side.
20. If necessary to replace ball bearing (Y), it can be pressed off shaft on an arbor press. In replacing the bearing it must be pressed on carefully until it seats against ground thrust washer (Z).

TO REMOVE CRANKSHAFT (Continued)

21. Carefully observing reverse of the foregoing operations should simplify reassembly of crankshaft. Checking exploded view drawings for location of various parts and constant testing for binds during reassembly will also prove helpful.
22. Before reassembling, thoroughly clean and dry the top and bottom covers and gaskets. Coat the oil drain plug with a sealing compound before reassembling to prevent oil leakage. No. 1 Crane Lead Seal is recommended.

ORDERING REPAIR PARTS

ILLUSTRATIONS

This catalog has been arranged to simplify ordering repair parts. Exploded views of various sections of the mechanism are shown so that the parts may be seen in their actual position in the machine. On the page opposite the illustration will be found a listing of the parts with their part numbers, description and the number of pieces required in the particular view being shown.

Numbers in the first column are reference numbers only, and merely indicate the position of that part in the illustration. Reference numbers should never be used in ordering parts. Always use the part number listed in the second column.

Component parts of sub-assemblies which can be furnished for repairs are indicated by indenting their descriptions under the description of the main sub-assembly. Example:

18	29477 MF	Crankshaft and Needle Driving Connecting Rod Assembly, for Styles 39800 CA and CB - - - - -	1
-	29477 MB	Crankshaft and Needle Driving Connecting Rod Assembly, for all Styles except 39800 CA and CB - - - - -	1
19	39852 A	Needle Driving Connecting Rod Assembly - - - - -	1
20	77	Screw - - - - -	1
21	22587 M	Screw - - - - -	2
22	39516-625	Needle Bearing, .0625 inch (1.588 mm) diameter - - -	-28
-	39516-626	Needle Bearing, .0626 inch (1.590 mm) diameter - - -	-28
-	39516-627	Needle Bearing, .0627 inch (1.593 mm) diameter - - -	-28
23	30-106 Blk.	Wood Plug, birch - - - - -	1
24	51-228 Blk.	Vent Plug - - - - -	1
25	39541 A	Feed Driving Eccentric Key - - - - -	1
26	C067 E	Cork Plug - - - - -	1
27	258	Nut - - - - -	1

In those cases where a part is common to all the machines covered by this catalog; no specific usage will be mentioned in the description. However, when the parts for the various machines are not the same, the specific usage will be mentioned in the description and, if necessary, the differences will be shown in the illustration.

At the back of the book will be found a numerical index of all the parts shown in this book. This will facilitate locating the illustration and description when only the part number is known.

## IDENTIFYING PARTS

When the construction permits, each part is stamped with its part number. Parts too small for a complete catalog stamping are identified by letter symbols which distinguish one part from another that is similar in appearance.

Part numbers represent the same part regardless of catalog in which they appear.

IMPORTANT! ON ALL ORDERS, PLEASE INCLUDE PART NAME AND STYLE OF MACHINE FOR WHICH PART IS ORDERED.

## USE GENUINE NEEDLES AND REPAIR PARTS

Success in the operation of these machines can be secured only with genuine UNION SPECIAL Needles and Repair Parts as furnished by the Union Special Corporation, its subsidiaries and authorized distributors. They are designed according to the most approved scientific principles, and are made with utmost precision. Maximum efficiency and durability are assured.

Genuine needles are packaged with labels marked *Union Special*<sup>®</sup>. Genuine repair parts are stamped with the Union Special trademark, U S Emblem. Each trademark is your guarantee of the highest quality in materials and workmanship.

## TERMS

Prices are strictly net cash and subject to change without notice. All shipments are forwarded f.o.b. shipping point. Parcel Post shipments are insured unless otherwise directed. A charge is made to cover postage and insurance.

## TORQUE REQUIREMENTS

Torque (measured in inch-pounds) is a rotating force (in pounds) applied through a distance by a lever (in inches or feet). This is accomplished by a wrench, screw driver, etc. Many of these devices are available, which when set at the proper amount of torque will tighten the part to the correct amount and no tighter.

All straps and eccentrics should be tightened to 19-21 inch-pounds (22-24 cm/kg) unless otherwise noted. All other nuts, bolts, screws, etc., should be tightened by hand as tightly as possible, unless otherwise noted.

The screws requiring a specific torque, will be indicated on the picture plates.

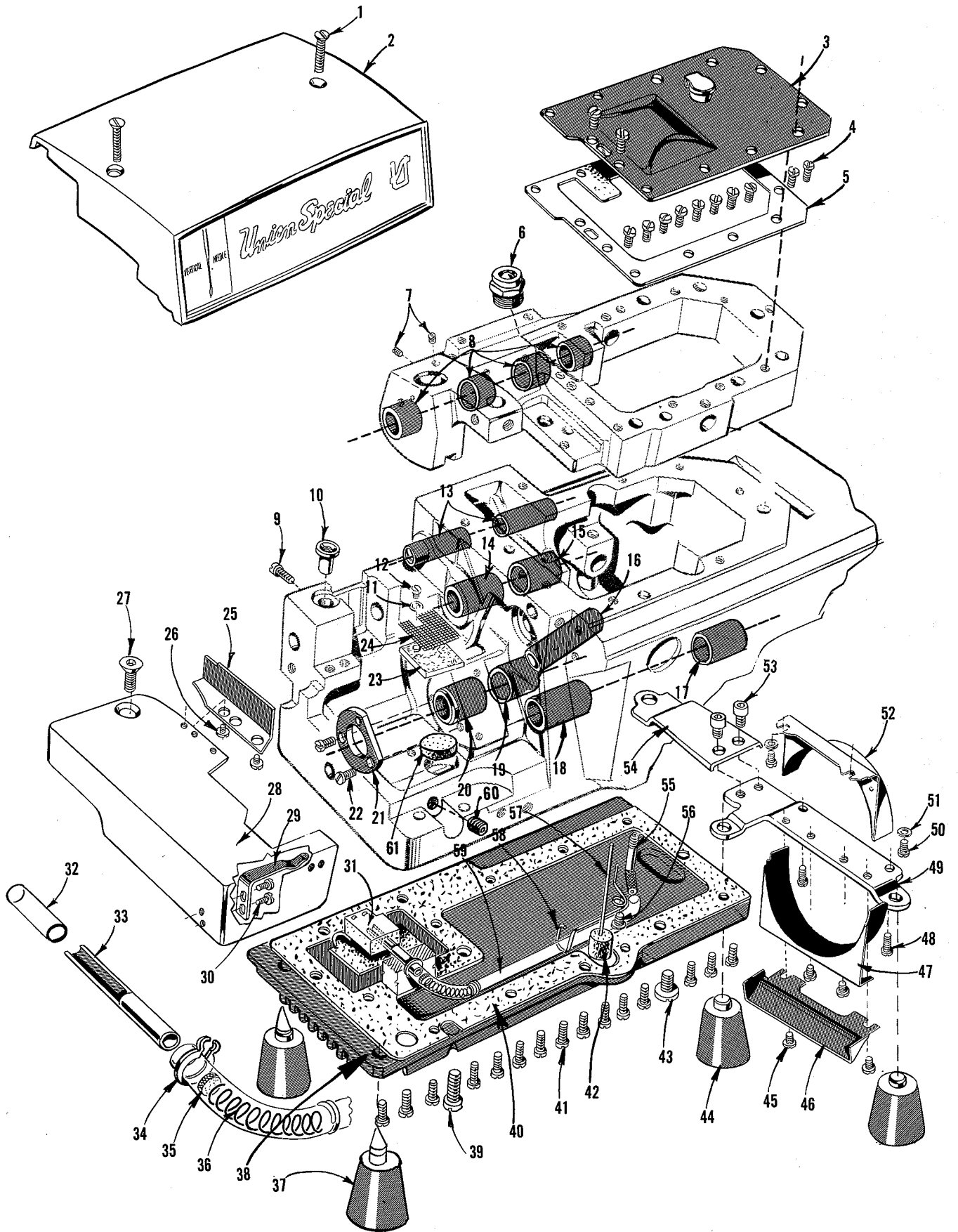



MAIN FRAME, MISCELLANEOUS COVERS, PLATES AND BUSHINGS

<u>Ref. No.</u>	<u>Part No.</u>	<u>Description</u>	<u>Amt. Req.</u>
1	22894 AG	Screw, for top cover - - - - -	2
2	39882 G	Top Cover - - - - -	1
3	39882 E	Upper Oil Shield Cover - - - - -	1
4	22541 B	Screw, for upper oil shield cover - - - - -	12
5	39882 F	Gasket, for upper oil shield cover - - - - -	1
6	39893 C	Oil Filler Screw Assembly - - - - -	1
7	88	Screw, for oil system - - - - -	2
8	39852 M	Needle Lever Drive Shaft Bushing - - - - -	4
9	22569	Screw, for cloth plate stud - - - - -	1
10	39501 K	Cloth Plate Stud - - - - -	1
11	8372 A	Washer, for oil filter screen screw - - - - -	1
12	22824 B	Screw, for oil filter screen - - - - -	1
13	39855 D	Foot Lifter Shaft Bushing - - - - -	2
14	39573 K	Upper Knife Driving Arm Bushing, left - - - - -	1
15	39573 AA	Upper Knife Driving Arm Bushing, right - - - - -	1
16	39544 L	Lower Looper Bar Bushing - - - - -	1
17	39644 C	40l Looper Drive Shaft Bushing, right - - - - -	1
18	39644 S	40l Looper Drive Shaft Bushing, left - - - - -	1
19	39590 T	Crankshaft Bushing, inner left - - - - -	1
20	39590	Crankshaft Bushing, left - - - - -	1
21	39834 B	Differential Feed Bar Thrust Washer - - - - -	1
22	22569 G	Screw, for feed bar thrust washer - - - - -	2
23	39894 B	Oil Strainer - - - - -	1
24	39894 A	Oil Filter Screen - - - - -	1
25	39578 F	Cloth Plate Fabric Guard - - - - -	1
26	138	Screw, for cloth plate fabric guard - - - - -	2
27	22657 D-12	Screw, for cloth plate - - - - -	1
28	39501 DN	Cloth Plate, for Styles 39800 CA, CB, CP, CQ, CX, CY - - - - -	1
-	39501 DU	Cloth Plate, for Styles 39800 VCP, VCQ, VCX, VCY (not shown) - - - - -	1
29	39832	Cloth Plate Latch Spring - - - - -	1
30	90	Screw, for cloth plate latch spring - - - - -	2
31	666-268	Felt Pad - - - - -	1
32	39593 K	Oil Tube, tygothane - - - - -	1
33	666-271	Oil Tube, brass - - - - -	1
34	660-506	Retaining Ring, for oil tube - - - - -	1
35	56393 G	Porex Filter, for oil tube - - - - -	1
36	56393 V	Spring, for oil tube - - - - -	1
37	51295 B	Isolator - - - - -	2
38	39882	Bottom Cover - - - - -	1
39	22806 A	Screw, for bottom cover - - - - -	1
40	39882 J	Bottom Cover Gasket - - - - -	1
41	22541 B	Screw, for bottom cover - - - - -	15
42	39593 C	Oil Gauge Float - - - - -	1
43	22586 R	Screw, for bottom cover - - - - -	1
44	39595	Isolator - - - - -	2
45	22569 D	Screw, for lower and outer air duct - - - - -	4
46	39582 BL	Air Duct, outer - - - - -	1
47	39582 BK	Air Duct, lower - - - - -	1
48	22541 B	Screw, for base plate - - - - -	2
49	39582 BM	Base Plate - - - - -	1
50	22569 C	Screw, for upper air duct - - - - -	2
51	8372 A	Washer, for upper air duct screw - - - - -	2
52	39582 BV	Air Duct, upper - - - - -	1
53	22653 D-4	Screw, for base plate extension - - - - -	2
54	39582 F	Base Plate Extension - - - - -	1
55	39593 J	Oil Pump Tube - - - - -	1
56	22569 D	Screw, for oil tube spring - - - - -	1
57	39593 D	Oil Gauge Indicator - - - - -	1
58	39593 L	Spring, for oil tube - - - - -	1
59	666-280	Oil Tube, tygothane - - - - -	1
60	22650 AE-4	Plug Screw - - - - -	1
61	666-290	Felt Disc - - - - -	1

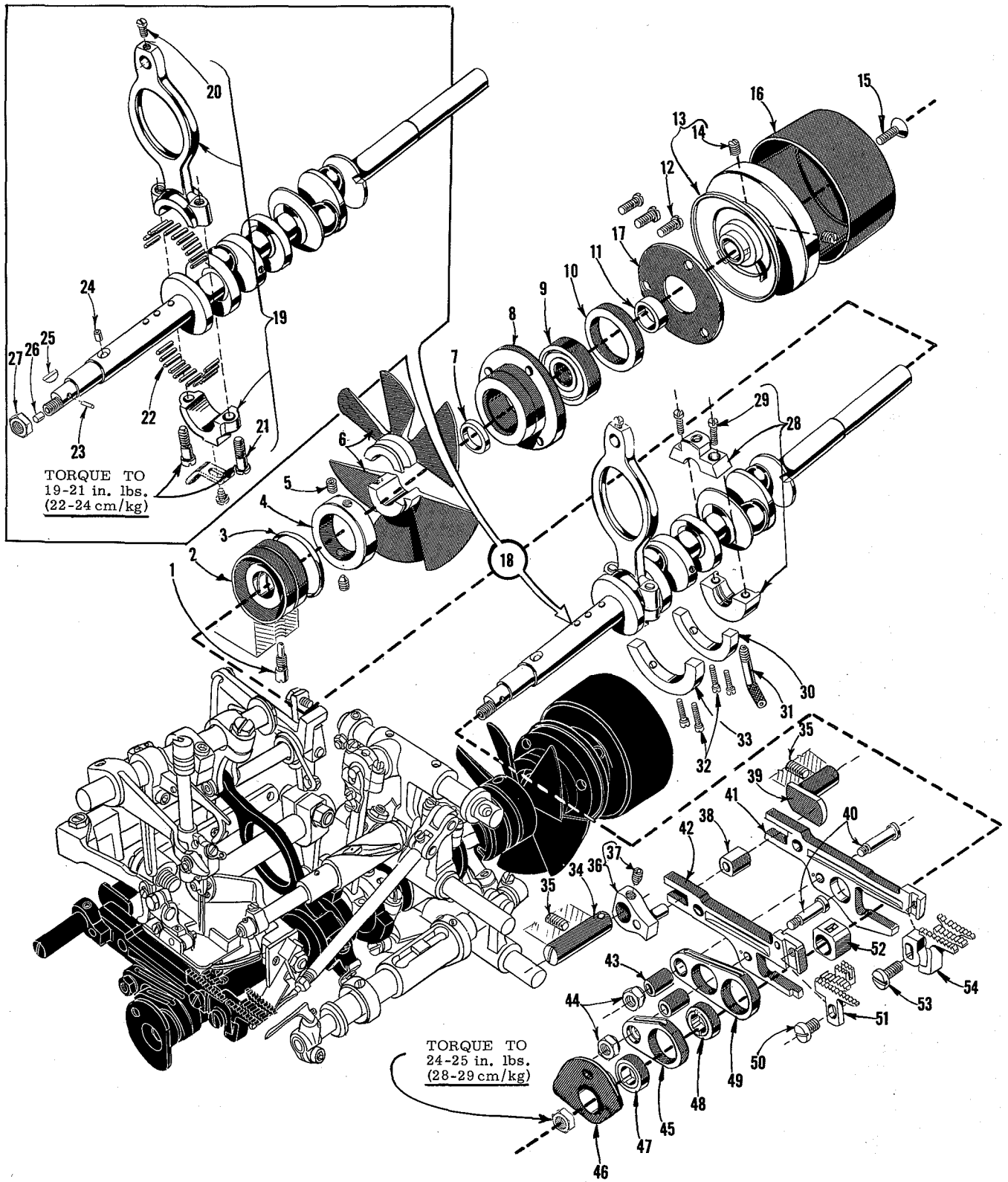

CRANKSHAFT AND FEED MECHANISM

<u>Ref.</u> <u>No.</u>	<u>Part</u> <u>No.</u>	<u>Description</u>	<u>Amt.</u> <u>Req.</u>
1	39690 A	Stud, for crankshaft bearing - - - - -	1
2	39890 C	Crankshaft Bearing, inner right - - - - -	1
3	660-443	"O" Ring, for crankshaft bearing, inner right - - - - -	1
4	39591 H	Crank Chamber Cooling Fan Collar - - - - -	1
5	22894 D	Spot Screw, for crank chamber cooling fan collar - - - - -	2
6	39591 L	Crank Chamber Cooling Fan - - - - -	1
7	39590 J	Thrust Washer - - - - -	1
8	39590 G	Crankshaft Ball Bearing Housing - - - - -	1
9	660-268	Crankshaft Ball Bearing - - - - -	1
10	39590 R	Ball Bearing Stop Collar - - - - -	1
11	39590 S	Spacer Collar - - - - -	1
12	22569 B	Screw, for ball bearing retaining plate and housing - - - - -	3
13	39521 G	Pulley - - - - -	1
14	95	Screw, for pulley - - - - -	2
15	22769 B	Screw, for pulley cap - - - - -	1
16	39821	Pulley Cap - - - - -	1
17	39590 H	Crankshaft Ball Bearing Retaining Plate - - - - -	1
18	29477 MF	Crankshaft and Needle Driving Connecting Rod Assembly, for Styles 39800 CA and CB - - - - -	1
-	29477 MB	Crankshaft and Needle Driving Connecting Rod Assembly, for all Styles except 39800 CA and CB - - - - -	1
19	39852 A	Needle Driving Connecting Rod Assembly - - - - -	1
20	77	Screw - - - - -	1
21	22587 M	Screw - - - - -	2
22	39516-625	Needle Bearing, .0625 inch (1.588 mm) diameter - - - - -	28
-	39516-626	Needle Bearing, .0626 inch (1.590 mm) diameter - - - - -	28
-	39516-627	Needle Bearing, .0627 inch (1.593 mm) diameter - - - - -	28
23	30-106 Blk.	Wood Plug, birch - - - - -	1
24	51-228 Blk.	Vent Plug - - - - -	1
25	39541 A	Feed Driving Eccentric Key - - - - -	1
26	C067 E	Cork Plug - - - - -	1
27	258	Nut - - - - -	1
28	39890 E	Split Bearing and Oil Pump - - - - -	1
29	97 A	Screw, for split bearing and oil pump - - - - -	2
30	39691	Crankshaft Counterweight, right - - - - -	1
31	39593 J	Oil Pump Tube - - - - -	1
32	22747 B	Screw, for crankshaft counterweight - - - - -	4
33	39591 K	Crankshaft Counterweight, left - - - - -	1
34	39835 B	Feed Adjusting Pin - - - - -	1
35	22894 J	Screw, for feed adjusting pin and feed bar guide, right - - - - -	2
36	39835 C	Feed Leveling Lever - - - - -	1
37	22894 U	Screw, for feed leveling lever - - - - -	1
38	39535 J	Feed Bar Guide Block - - - - -	1
39	39835 A	Feed Bar Guide, right - - - - -	1
40	39536 B	Feed Bar Driving Stud - - - - -	2
41	39534 G	Differential Feed Bar - - - - -	1
42	39534	Main Feed Bar - - - - -	1
43	39536 C	Feed Bar Driving Stud Bushing - - - - -	2
44	39536 E	Nut, for feed bar driving stud - - - - -	2
45	39536 AF	Main Feed Bar Driving Connection - - - - -	1
46	39868 R	401 Looper Thread Take-up - - - - -	1
47	39540 B-10	Main Feed Driving Eccentric, for No. 5 1/8 gauge, all Styles - - - - -	1
-	39540 B-8	Main Feed Driving Eccentric, for No. 8 3/16 or 12 3/16 gauge, all Styles - - - - -	1
48	39540 B-10	Differential Feed Driving Eccentric, for No. 5 1/8 gauge, all Styles - - - - -	1
-	39540 B-8	Differential Feed Driving Eccentric, for No. 8 3/16 or 12 3/16 gauge, all Styles - - - - -	1
49	39536 AE	Differential Feed Bar Driving Connection - - - - -	1
50	93 A	Screw, for main feed dog - - - - -	1
51		Main Feed Dog (See Pages 43 and 45) - - - - -	1
52	39838	Feed Lift Block - - - - -	1
53	93	Screw, for differential feed dog - - - - -	1
54		Differential Feed Dog (See Pages 43 and 45) - - - - -	1

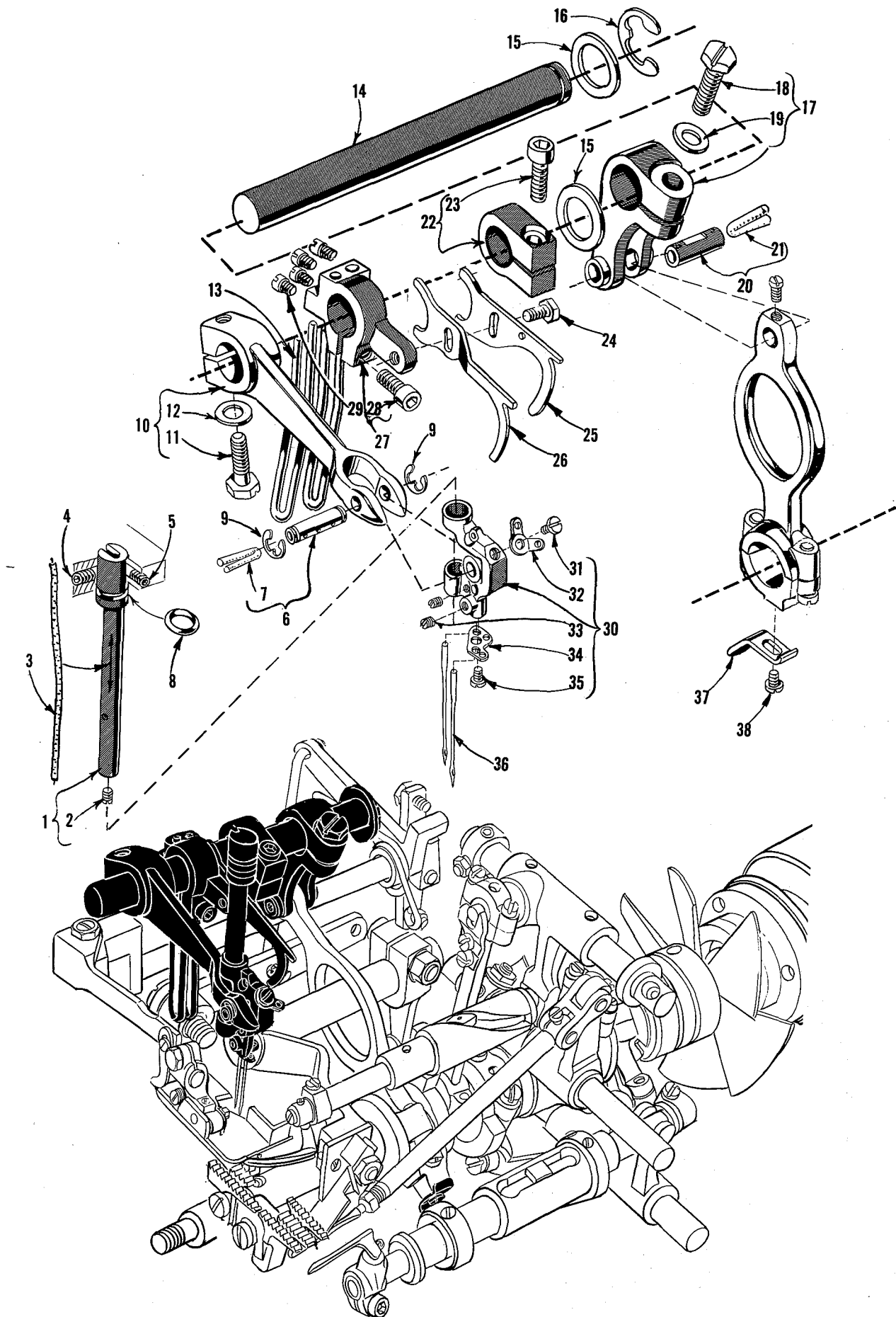

NEEDLE DRIVE MECHANISM AND TAKE-UPS

<u>Ref. No.</u>	<u>Part No.</u>	<u>Description</u>	<u>Amt. Req.</u>
1	39852 J	Needle Guide Bar - - - - -	1
2	22733	Screw, for needle guide bar - - - - -	1
3	CL21	Pipe Cleaner (oil wick) - - - - -	1
4	22894 C	Set Screw - - - - -	1
5	22894 L	Spot Screw - - - - -	1
6	39852 C	Needle Lever Roller Pin - - - - -	1
7	WO-3	Wool Yarn - - - - - as required	
8	660-220	"O" Ring, for needle guide bar - - - - -	1
9	660-416	Retaining Ring, for needle lever roller pin - - - - -	2
10	39852	Needle Lever - - - - -	1
11	22852 C	Screw, for needle lever - - - - -	1
12	40-139	Washer, for needle lever - - - - -	1
13	39863 C	Lower Looper Thread Take-up Wire - - - - -	2
14	39852 E	Needle Lever Drive Shaft - - - - -	1
15	39573 A	Thrust Washer - - - - -	2
16	660-442	Retaining Ring, for needle lever drive shaft - - - - -	1
17	39852 D	Needle Drive Lever - - - - -	1
18	22852 C	Screw, for needle drive lever - - - - -	1
19	40-139	Washer, for needle drive lever - - - - -	1
20	51236 A	Link Pin, for needle drive lever - - - - -	1
21	WO-3	Wool Yarn - - - - - as required	
22	39843 D	Needle Lever Drive Shaft Thrust Clamp Collar - - - - -	1
23	22652 B-10	Screw, for thrust clamp collar - - - - -	1
24	22588 A	Screw, for needle thread cam pull-off - - - - -	1
25	39863 D	503 Needle Thread Cam Pull-off - - - - -	1
26	39863 J	401 Needle Thread Cam Pull-off - - - - -	1
27	39863	Lower Looper Thread Take-up Lever - - - - -	1
28	22752 B	Screw, for take-up lever - - - - -	1
29	22564 D	Screw, for take-up lever wire - - - - -	4
30	39852 F-5	Needle Head, marked "AV", for No. 5 1/8 gauge, all Styles - - - - -	1
-	39852 F-8	Needle Head, marked "BN", for No. 8 3/16 gauge, all Styles - - - - -	1
-	39852 F-12	Needle Head, marked "AW", for No. 12 3/16 gauge, all Styles - - - - -	1
31	22784 L	Screw, for top needle head eyelet - - - - -	1
32	39852 N	Needle Head Eyelet, top - - - - -	1
33	28 C	Screw, for needles - - - - -	2
34	39852 K-5	Needle Head Eyelet, for No. 39852 F-5 - - - - -	1
-	39852 K-8	Needle Head Eyelet, for No. 39852 F-8 - - - - -	1
-	39852 K-12	Needle Head Eyelet, for No. 39852 F-12 - - - - -	1
35	22738 B	Screw for 39852 F-5 or 39852 F-8 - - - - -	1
-	605	Screw, for No. 39852 F-12 - - - - -	1
36	120 GS	Needle, for all 5 1/8, 8 3/16 gauge machines; 12 3/16 gauge on Styles 39800 CA and CB - - - - -	2
-	120 GAS	Needle, for all 12 3/16 gauge machines except Styles 39800 CA and CB - - - - -	2
37	39594 N	Oil Splasher - - - - -	1
38	87 U	Screw, for oil splasher - - - - -	1

TORQUE TO  
19-21 in. lbs.  
(22-24 cm/kg)

TORQUE TO  
19-21 in. lbs.  
(22-24 cm/kg)

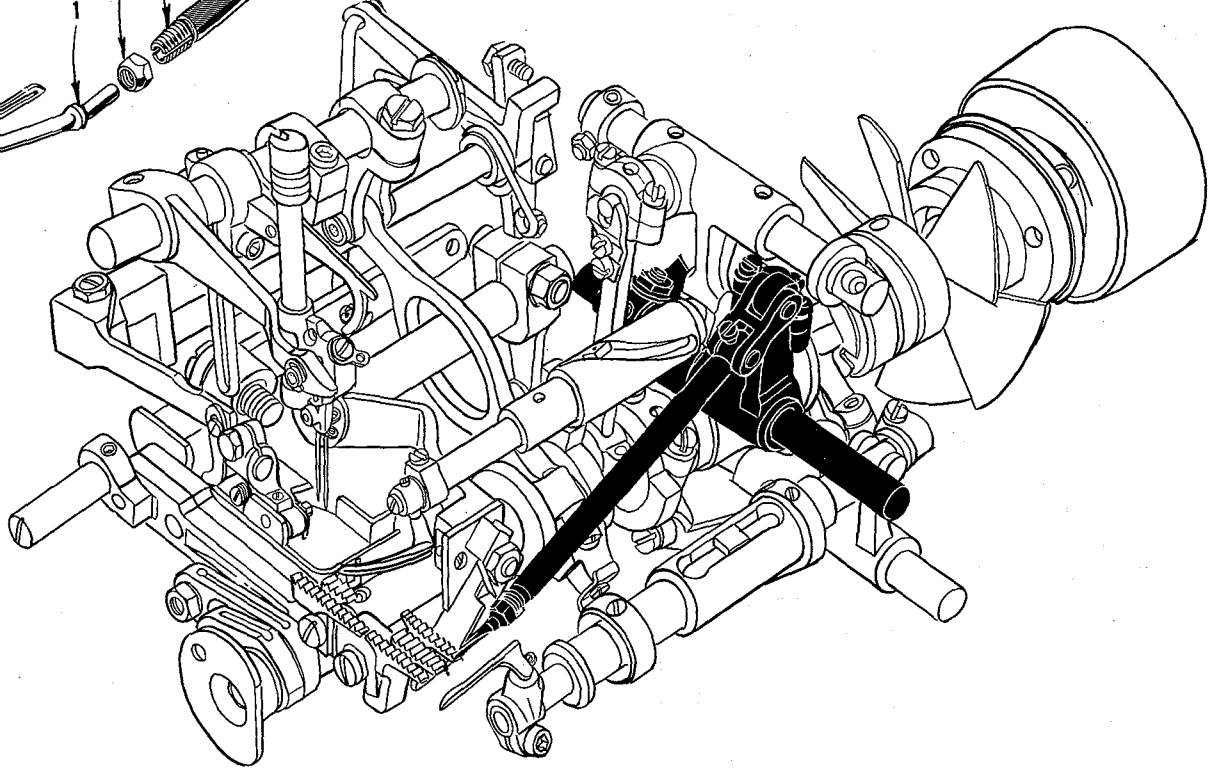
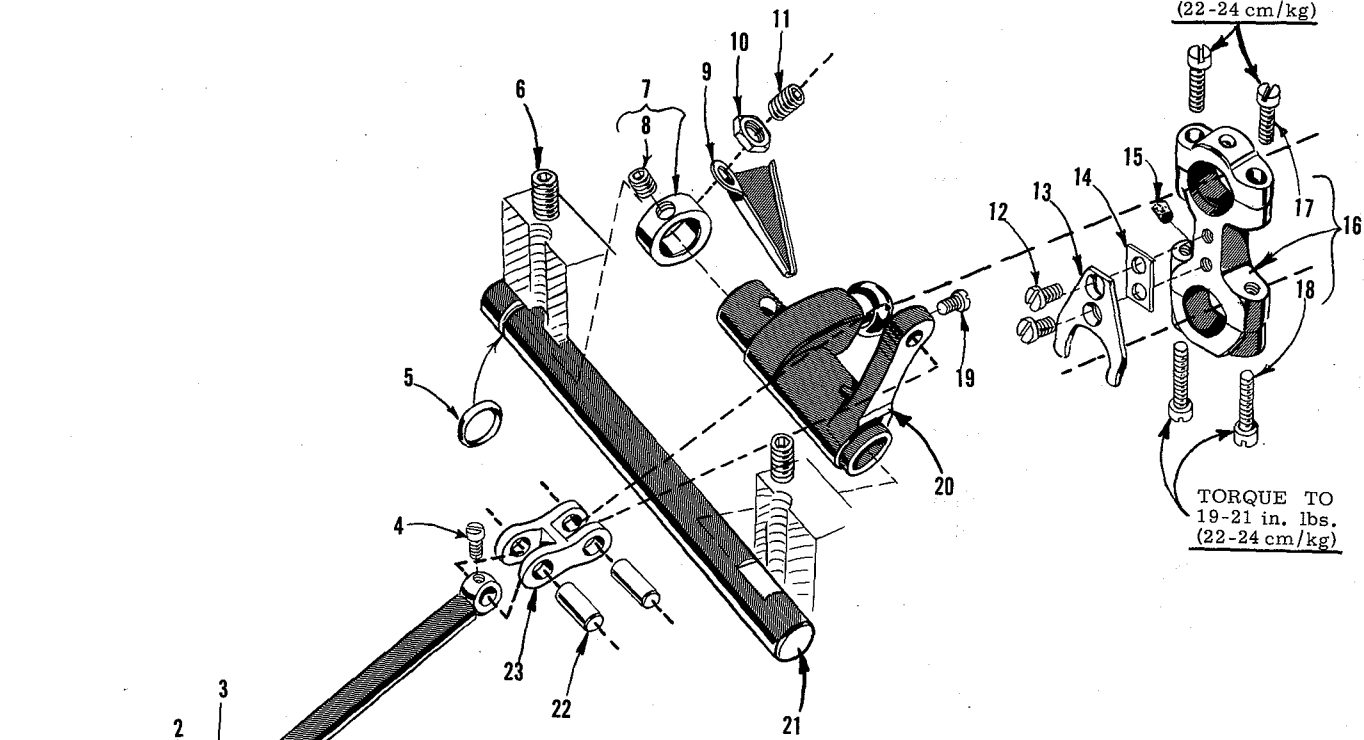

LOWER LOOPER DRIVING MECHANISM

<u>Ref. No.</u>	<u>Part No.</u>	<u>Description</u>	<u>Amt. Req.</u>
1	39808 D	Lower Looper, marked "ACZ" - - - - -	1
2	39151	Nut, for lower looper bar - - - - -	1
3	52344	Lower Looper Bar - - - - -	1
4	77	Screw, for connecting link pin - - - - -	1
5	660-206	"O" Ring, for lower looper bar driving lever shaft - - - - -	1
6	22894 AE	Screw, for lower looper bar driving lever shaft - - - - -	2
7	482 C	Lower Looper Shaft Collar - - - - -	1
8	22894 C	Screw, for collar - - - - -	2
9	39894 C	Oil Pump Oiler - - - - -	1
10	12982	Nut, for oil pump oiler screw - - - - -	1
11	22894 J	Screw, for oil pump oiler - - - - -	1
12	538	Screw, for ball joint guide fork - - - - -	2
13	39644 X	Ball Joint Guide Fork - - - - -	1
14	39644 R-2	Shim, for ball joint guide fork, .002 inch (.051 mm) thick - - - - -	as required
-	39644 R-5	Shim, for ball joint guide fork, .005 inch (.127 mm) thick - - - - -	as required
15	666-255	Felt Plug, for lower looper drive lever connecting rod - - - - -	1
16	39644 F	Lower Looper Drive Lever Connecting Rod - - - - -	1
17	22729 D	Screw, for connecting rod - - - - -	2
18	22729 E	Screw, for connecting rod - - - - -	2
19	77	Screw, for connecting link pin - - - - -	1
20	39844	Lower Looper Bar Driving Lever - - - - -	1
21	39844 B	Lower Looper Bar Driving Lever Shaft - - - - -	1
22	39544 D	Lower Looper Bar Connecting Link Pin - - - - -	2
23	39544 B	Lower Looper Bar Connecting Link - - - - -	1

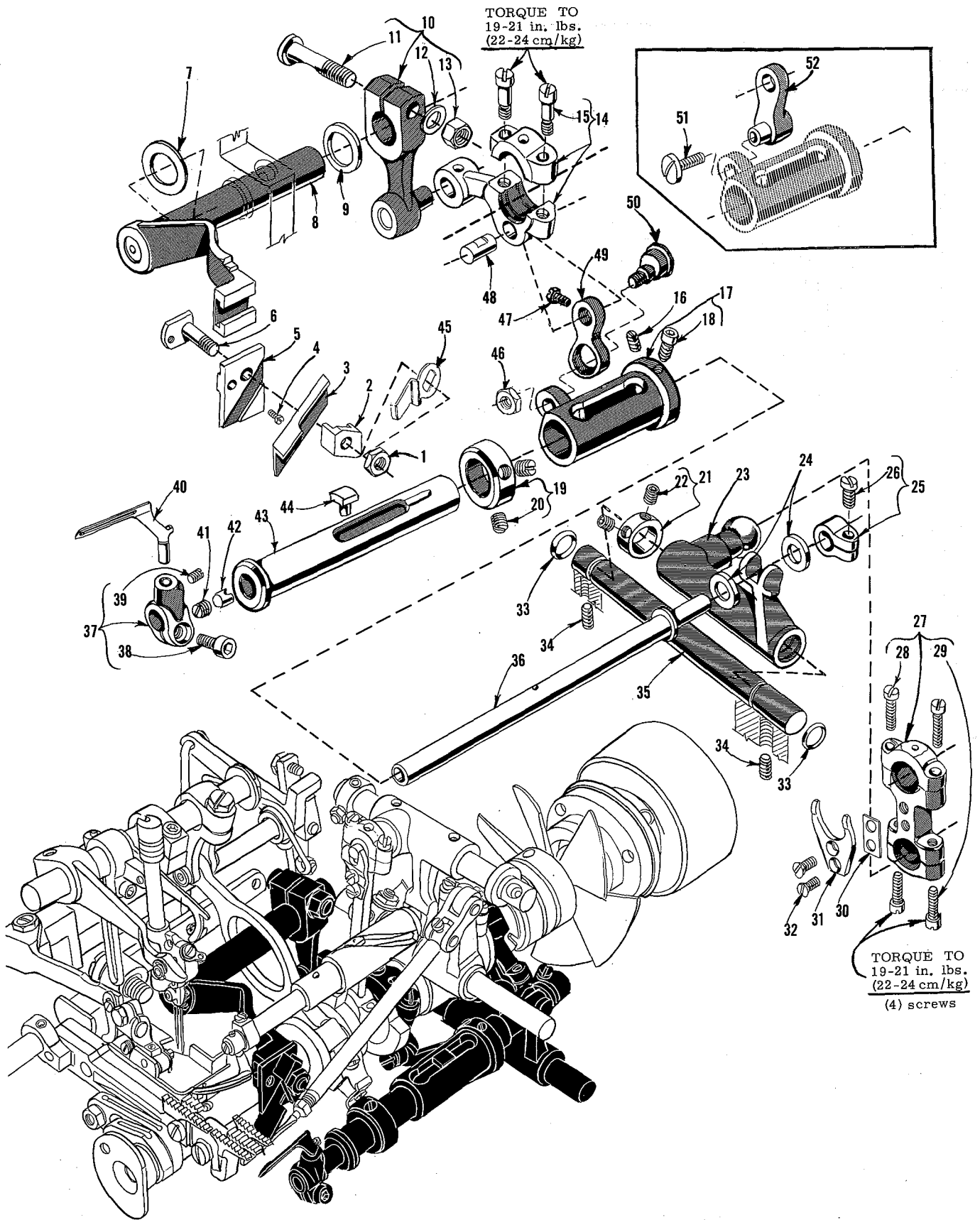



UPPER KNIFE AND 401 LOOPER DRIVING MECHANISM

<u>Ref. No.</u>	<u>Part No.</u>	<u>Description</u>	<u>Amt. Req.</u>
1	9937	Nut, for upper knife clamp stud - - - - -	1
2	39871	Upper Knife Clamp - - - - -	1
3	39870	Upper Knife - - - - -	1
4	22738	Screw, for upper knife clamp stud - - - - -	1
5	39572 A	Upper Knife Holder Block - - - - -	1
6	39571 C	Upper Knife Clamp Stud - - - - -	1
7	39873 B	Upper Knife Driving Arm Thrust Washer - - - - -	1
8	39873	Upper Knife Driving Arm - - - - -	1
9	39573 A	Upper Knife Driving Arm Thrust Washer - - - - -	1
10	39573 E	Upper Knife Driving Lever - - - - -	1
11	55235 D	Locking Stud, for driving lever - - - - -	1
12	6042 A	Washer, for driving lever - - - - -	1
13	55235 E	Nut, for driving lever - - - - -	1
14	39673	Upper Knife Driving Lever Connecting Rod - - - - -	1
15	22587 E	Screw, for connecting rod - - - - -	2
16	22565 C	Set Screw, for bushing and cam guide - - - - -	1
17	39644 K	Bushing and Cam Guide, for Styles 39800 CA and CB - - - - -	1
-	39644 V	Bushing and Cam Guide, for all Styles except 39800 CA and CB - - - - -	1
18	22729 M	Screw, for bushing and cam guide - - - - -	1
19	39644 P	Thrust Collar - - - - -	1
20	98	Screw, for thrust collar - - - - -	2
21	482 C	Looper Drive Lever Shaft Collar - - - - -	1
22	22894 C	Screw, for collar - - - - -	2
23	39644	Looper Drive Lever - - - - -	1
24	39543 P	Looper Bar Thrust Washer - - - - -	2
25	39543 M	Clamp Collar - - - - -	1
26	22562 A	Screw, for clamp collar - - - - -	1
27	39644 U	Looper Drive Lever Auxiliary Connecting Rod - - - - -	1
28	22729 E	Screw, for connecting rod - - - - -	2
29	22729 D	Screw, for connecting rod - - - - -	2
30	39644 R-2	Shim, for ball joint guide fork, .002 inch (.051 mm) thick - - - - -	as required
-	39644 R-5	Shim, for ball joint guide fork, .005 inch (.127 mm) thick - - - - -	as required
31	39644 X	Ball Joint Guide Fork - - - - -	1
32	538	Screw, for ball joint guide fork - - - - -	2
33	660-206	"O" Ring, for looper drive lever shaft - - - - -	2
34	22894 AE	Screw, for looper drive lever shaft - - - - -	2
35	39644 N	Looper Drive Lever Shaft - - - - -	1
36	39644 A	Looper Bar (401 stitch) - - - - -	1
37	39844 A	Looper Holder, for 401 stitch looper - - - - -	1
38	22652 A-6	Screw, for looper holder - - - - -	1
39	22894 AF	Screw, for looper - - - - -	1
40	39808	Looper, marked "CY", for 401 stitch - - - - -	1
41	22503 F	Screw, for cam follower locking clamp - - - - -	1
42	39543 E	Cam Follower Locking Clamp - - - - -	1
43	39644 W	Looper Bar Sleeve - - - - -	1
44	39644 L	Cam Follower - - - - -	1
45	39571 B	Upper Knife Chain Guard - - - - -	1
46	39536 E	Nut, for looper avoid eccentric stud - - - - -	1
47	22781	Screw, for looper avoid link pin - - - - -	1
48	41336 C	Looper Avoid Link Pin - - - - -	1
49	39844 C	Looper Avoid Link - - - - -	1
50	39844 D	Looper Avoid Eccentric Stud - - - - -	1
*51	22775	Screw, for looper avoid link- - - - -	1
*52	39644 M	Looper Avoid Link - - - - -	1

\* Used on earlier model machines, in place of Ref. Nos. 46, 49 and 50.

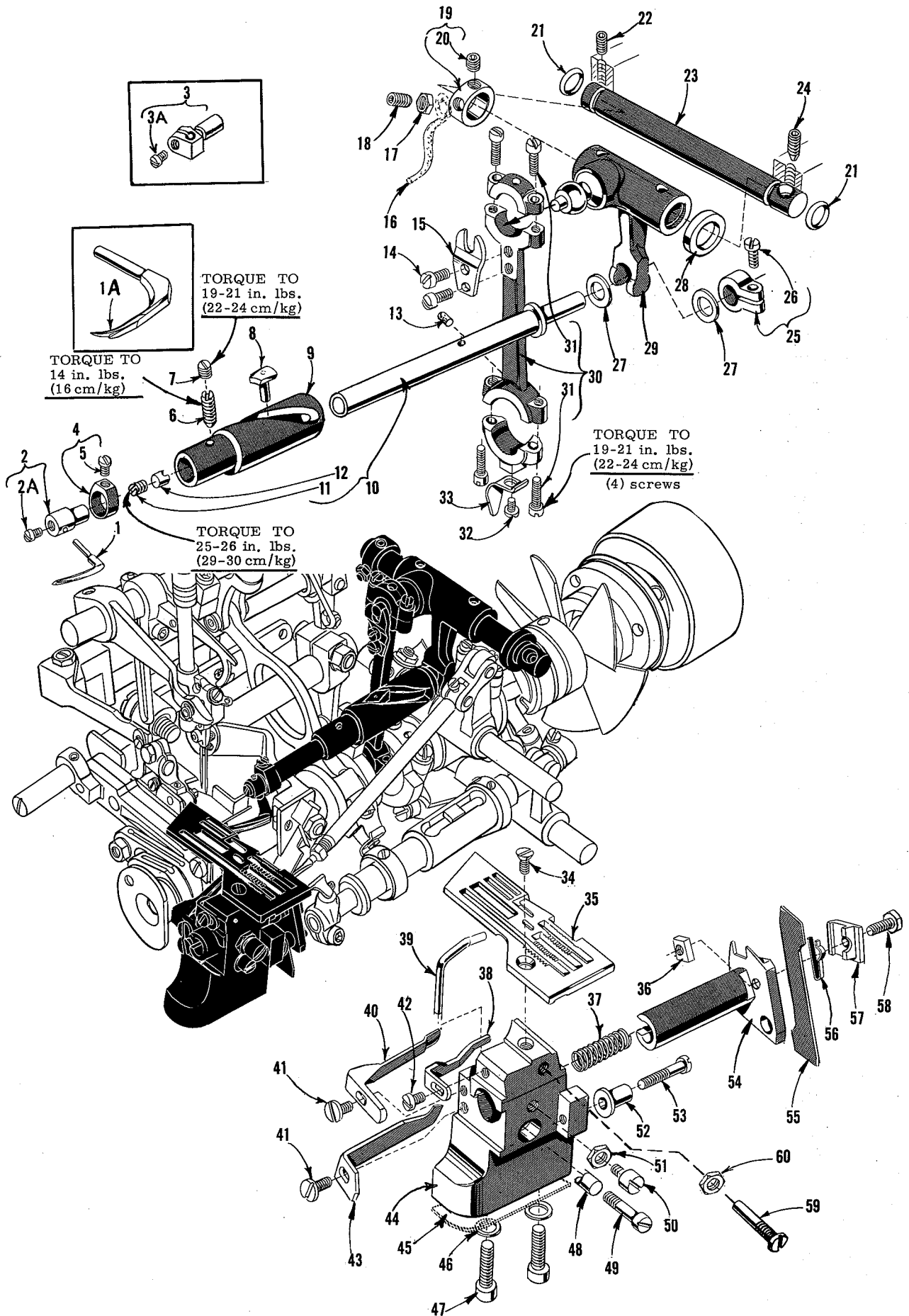

UPPER LOOPER OR SPREADER DRIVE, NEEDLE GUARDS, THROAT  
PLATES AND LOWER KNIFE PARTS

Ref. No.	Part No.	Description	Amt. Req.
1	39808 A	Upper Looper, marked "DA", for 100/040 needle size and smaller, for Styles 39800 CB, CQ, CY, VCQ, and VCY; all gauges	1
-	39808 C	Upper Looper, marked "ADA", for 110/044 needle size and larger, for Styles 39800 CB, CQ, CY, VCQ and VCY; all gauges	1
1A	39860	Upper Spreader, marked "H", for Styles 39800 CA, CP, CX, VCP and VCX; all gauges	1
2	39543	Upper Looper or Spreader Holder, marked "J"	1
2A	22564 G	Screw, for upper looper or spreader	1
** 3	39543 H	Upper Looper or Spreader Holder	1
3A	22768 B	Screw, for upper looper or spreader	1
4	39543 H	Upper Looper or Spreader Holder Collar	1
5	22 KH	Screw, for upper looper or spreader holder collar	1
6	22565 R	Screw, for bushing and cam guide	1
7	1025 L	Lock Screw, for bushing and cam guide screw	1
8	39543 T	Cam Follower	1
* 9	39543 S	Upper Looper or Spreader Drive Shaft Bushing and Cam Guide	1
*10	39843 A	Upper Looper or Spreader Drive Shaft	1
11	22503 F	Screw, for cam follower locking clamp	1
12	39543 E	Cam Follower Locking Clamp	1
13	666-255	Felt Plug, for upper looper or spreader drive lever connecting rod	1
14	97	Screw, for guide fork	2
15	39544 J	Guide Fork	1
16	WO-3	Wool Yarn, for head	as required
17	12982	Nut	1
18	22894 J	Screw	1
19	482 C	Upper Looper or Spreader Drive Lever Shaft Collar	1
20	22894 C	Screw, for collar	2
21	660-206	"O" Ring, for upper looper or spreader drive lever shaft	2
22	22894 C	Set Screw, for upper looper or spreader drive lever shaft	1
23	39843 C	Upper Looper or Spreader Drive Lever Shaft	1
24	22894 L	Spot Screw, for upper looper or spreader drive lever shaft	1
25	39543 M	Clamp Collar	1
26	22562 A	Screw, for clamp collar	1
27	39543 P	Thrust Washer, for upper looper or spreader drive shaft, for Styles 39800 CA and CB	2
-	39843 E	Thrust Washer, for upper looper or spreader drive shaft, for all Styles except 39800 CA and CB	2
28	39843 B	Upper Looper or Spreader Drive Lever Thrust Washer	1
29	39543 W	Upper Looper or Spreader Drive Lever	1
30	39843	Upper Looper or Spreader Drive Lever Connecting Rod	1
31	22729 D	Screw, for connecting rod	4
32	87 U	Screw, for oil splasher	1
33	39594 N	Oil Splasher	1
34	22524	Screw, for throat plate	1
35		Throat Plate, (See Pages 43 and 45)	1
36	39650 A	Lower Knife Clamp Screw Nut	1
37	39550 E	Knife Holder Spring	1
38	39625 D	Needle Guard, front, for 401 stitch needle	1
39	39825 C	Needle Guard, rear, for 401 stitch needle	1
40	39825 B	Needle Guard, rear, for 503 or 504 stitch needle	1
41	22585 A	Screw, for 503 or 504 stitch needle guard	2
42	90	Screw, for 401 stitch front needle guard	1
43	39825	Needle Guard, front, for 503 or 504 stitch needle	1
44	39880	Throat Plate and Lower Knife Support Bracket	1
45	39880 H	Shim, for throat plate support bracket	as required
46	39580 F	Washer, for support bracket screw	2
47	22653 B-12	Screw, for support bracket	2
48	39543 E	Needle Guard Locking Clamp	1
49	88 F	Screw, for needle guard locking clamp	1
50	22892 B	Locking Screw, for lower knife holder	1
51	14077	Nut, for locking screw	1
52	39550 C	Lower Knife Holder Locating Stud	1
53	22729 B	Screw, for lower knife holder locating stud	1
54	39650	Lower Knife Holder	1
55	39849	Lower Knife	1
56	39550 M	Lower Knife Clamp Spring	1
57	39550 Z	Lower Knife Clamp	1
58	22588 J	Screw, for lower knife clamp	1
59	39883	Screw, for stabilizing 401 stitch front needle guard	1
60	41071 G	Nut, locking	1

\* Replacement with assembly No. 29126 EK is recommended, instead of the individual parts.  
 \*\* Upper Looper or Spreader Holder No. 39843 H is used on later model machines.

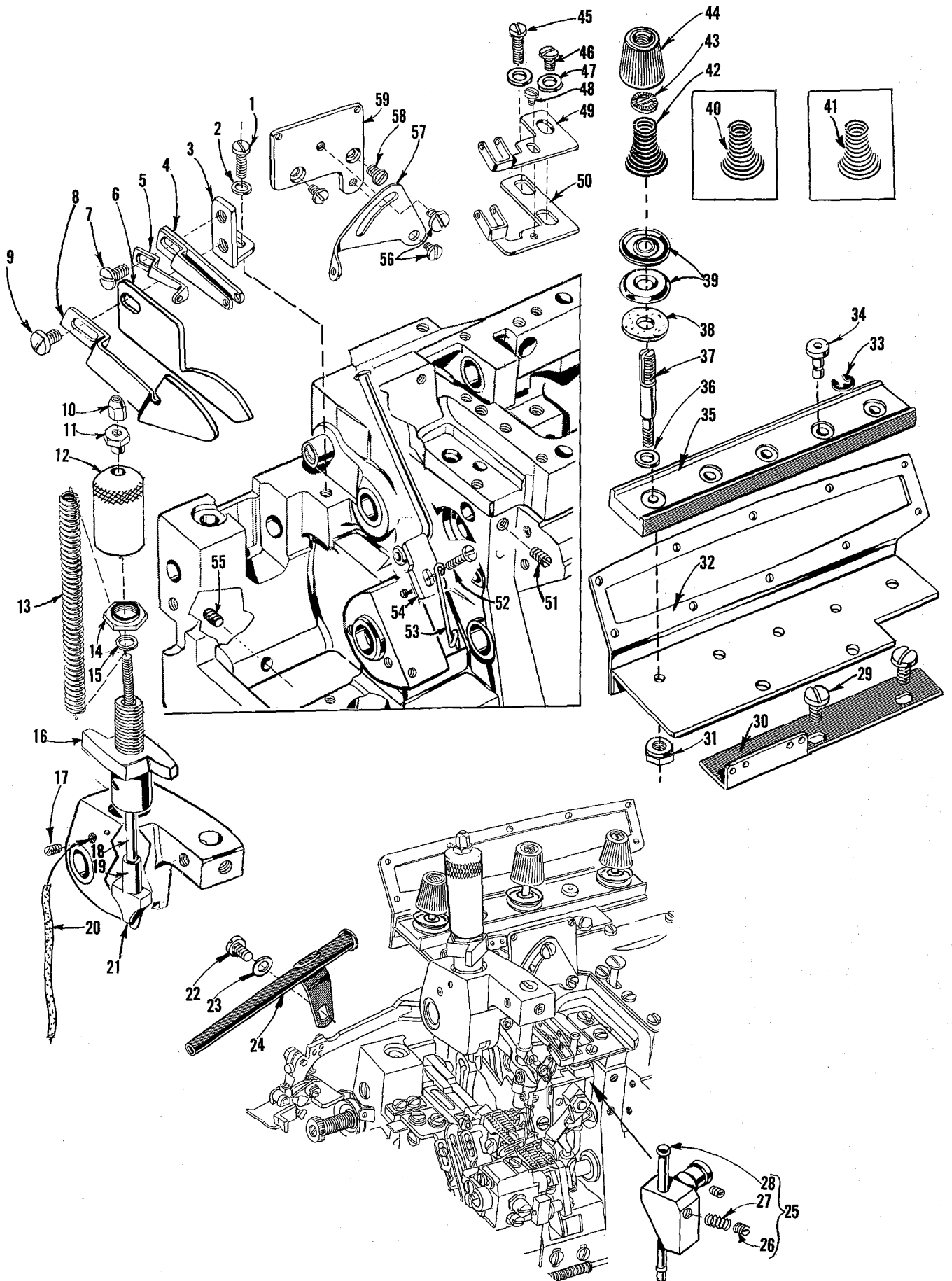

THREAD TENSIONS, EYELETS AND PRESSER SPRING PARTS

Ref. No.	Part No.	Description	Amt. Req.
1	22569 B	Screw, for eyelet and fabric guard mounting bracket - - - - -	1
2	53634 C	Washer, for mounting bracket screw - - - - -	1
3	39868 D	Upper Looper Thread Eyelet and Fabric Guard Mounting Bracket - - - - -	1
4	39568 L	Upper Looper Take-up Eyelet, on Styles 39800 CB, CQ, CY, VCQ and VCY; all gauges - - - - -	1
5	39568 E	Auxiliary Upper Looper Thread Eyelet, on Styles 39800 CB, CQ, CY, VCQ and VCY; all gauges - - - - -	1
6	39868 X	Lower Looper Cast-off Blade - - - - -	1
7	376 A	Screw, for upper looper take-up eyelet on Styles 39800 CB, CQ, CY, VCQ and VCY; all gauges - - - - -	1
8	39868 Y	Fabric Guard - - - - -	1
9	376 A	Screw, for fabric guard - - - - -	1
10	39557 B	Presser Spring Plunger Cap Nut - - - - -	1
11	39857 L	Presser Spring Plunger Lock Nut - - - - -	1
12	39857 N	Presser Spring Plunger Adjusting Screw - - - - -	1
13	39857 C	Presser Spring, heavy, for all Styles except 39800 CA and CB - - - - -	1
-	39857 P	Presser Spring, light, for Styles 39800 CA and CB - - - - -	1
14	51257 H	Lock Nut, for plunger adjusting screw - - - - -	1
15	39857 E	Washer - - - - -	1
16	39856 B	Presser Foot Release Lever - - - - -	1
17	95	Screw, for oil system - - - - -	1
18	39857 J	Presser Spring Plunger Stud - - - - -	1
19	39857 M	Spacer - - - - -	1
20	CL21	Pipe Cleaner (oil wick) - - - - -	1
21	39857 A	Presser Spring Plunger Head - - - - -	1
22	22569 D	Screw, for thread tube - - - - -	1
23	53634 C	Washer, for thread tube screw - - - - -	1
24	39868 N	Thread Tube, for 401 looper thread - - - - -	1
25	29477 MA	Upper Looper Thread Tube Assembly - - - - -	1
26	22743	Screw, for thread tube tension spring - - - - -	1
27	39568 J	Thread Tube Tension Spring - - - - -	1
28	39568 P	Thread Tube - - - - -	1
29	22548	Screw, for thread guide and mounting bracket - - - - -	2
30	39892 B	Thread Guide, front - - - - -	1
31	39592 AH	Nut, for thread tension post - - - - -	3 or 4
32	39892 A-5	Tension Post Mounting Bracket - - - - -	1
33	660-469	Retaining Ring, for tension post bar eyelet - - - - -	1
34	39892 C	Tension Post Bar Eyelet - - - - -	1
35	39592 AN	Tension Post Bar - - - - -	1
36	8372 A	Washer, for thread tension post - - - - -	3 or 4
37	39592 AL	Thread Tension Post - - - - -	3 or 4
38	39592 AF	Tension Disc Felt - - - - -	3 or 4
39	39592 AD	Thread Tension Disc - - - - -	6 or 8
40	39592 AR-2	Tension Spring, for 503 stitch needle on Styles 39800 CA, CP, CX, VCP and VCX - - - - -	1
41	39592 AR-4	Tension Spring, for 503 stitch looper on Styles 39800 CA, CP, CX, VCP and VCX - - - - -	1
-	39592 AR-4	Tension Spring, for 504 stitch needle on Styles 39800 CB, CQ, CY, VCQ and VCY - - - - -	1
-	39592 AR-4	Tension Spring, for 504 stitch looper on Styles 39800 CB, CQ, CY, VCQ and VCY - - - - -	2
42	39592 AR-5	Tension Spring, for 401 stitch needle - - - - -	1
43	39592 AK	Tension Spring Ferrule - - - - -	3 or 4
44	39592 Y	Upper Looper Tension Nut, black, for Styles 39800 CB, CQ, CY, VCQ and VCY - - - - -	1
-	39592 Z	Lower Looper Tension Nut, golden beige - - - - -	1
-	39592 AA	Overedge Needle Tension Nut, green - - - - -	1
-	39592 AC	401 Stitch Needle Tension Nut, red - - - - -	1
45	22541 D	Screw, for 401 stitch needle thread pull-off eyelet - - - - -	1
46	22569 C	Screw, for overedge needle thread pull-off eyelet - - - - -	1
47	8372 A	Washer, for Nos. 22541 D and 22596 C - - - - -	2
48	22704	Screw, for 401 stitch needle thread pull-off eyelet - - - - -	1
49	39863 K	401 Stitch Needle Thread Pull-off Eyelet - - - - -	1
50	39863 L	Overedge Needle Thread Pull-off Eyelet - - - - -	1
51	22565	Screw, for upper looper thread tube assembly - - - - -	1
52	22585 R	Screw - - - - -	1
53	39868 H	Pigtail Eyelet, for 401 stitch looper thread - - - - -	1
54	39868 Z	Thread Tube, for 503 or 504 stitch looper thread - - - - -	1
55	22591	Screw, for oil system - - - - -	1
56	HS24 C	Screw, for adjustable needle thread eyelet - - - - -	2
57	39863 N	Adjustable Needle Thread Eyelet - - - - -	1
58	22564 J	Screw, for needle thread frame eyelet - - - - -	2
59	39863 M	Needle Thread Frame Eyelet - - - - -	1

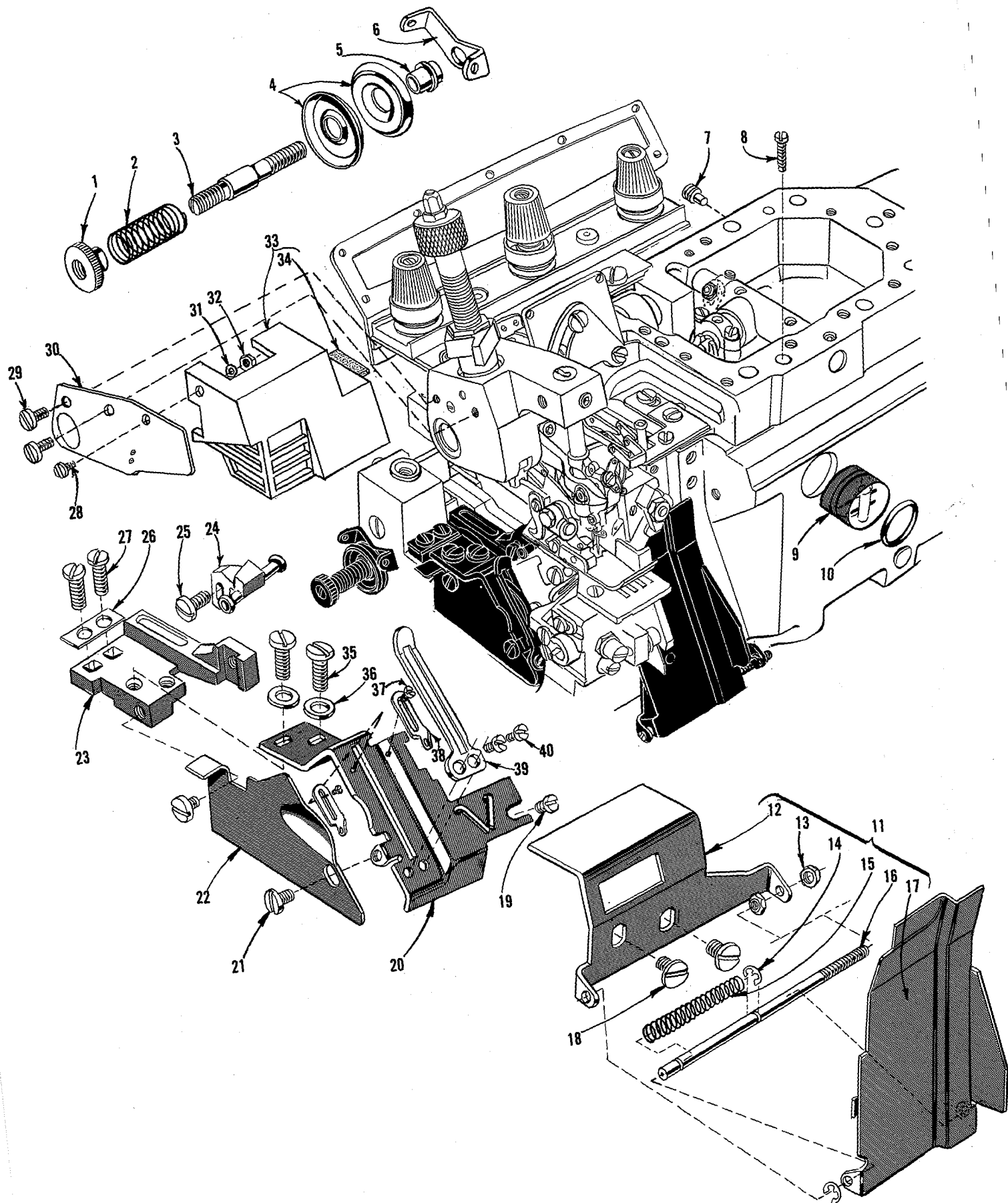

401 LOOPER TENSION PARTS, MISCELLANEOUS PLATES AND GUARDS

<u>Ref.</u> <u>No.</u>	<u>Part</u> <u>No.</u>	<u>Description</u>	<u>Amt.</u> <u>Req.</u>
1	51292 C	401 Stitch Looper Tension Nut- - - - -	1
2	51292 F-2	Tension Spring, for 401 looper - - - - -	1
3	51292 G	Thread Tension Post - - - - -	1
4	109	Thread Tension Disc - - - - -	2
5	51292 A	Ferrule - - - - -	1
6	51292 D	Tension Thread Eyelet - - - - -	1
7	22571 E	Magnetic Oil Drain Plug- - - - -	1
8	22569 K	Screw, for oil sight gauge - - - - -	1
9	39893	Oil Sight Gauge - - - - -	1
10	660-243	Oil Gauge Seal Ring - - - - -	1
11	39878 E	Chip Guard Assembly - - - - -	1
12	39878 F	Chip Guard Base - - - - -	1
13	43443 Q	Nut, for hinge pin - - - - -	2
14	660-210	Retaining Ring - - - - -	2
15	39158 U	Spring - - - - -	1
16	39878 C	Hinge Pin - - - - -	1
17	39878 G	Chip Guard Cover - - - - -	1
18	22569 D	Screw, for chip guard - - - - -	2
19	22585	Screw, for cast-off support plate - - - - -	1
20	39868 B	Cast-off Support Plate - - - - -	1
21	22585 C	Screw, for support plate end cover - - - - -	2
22	39868 M	Support Plate End Cover - - - - -	1
23	39835 D	Main Feed Bar Guide, left, for machines w/o "Air-Klipp" - - - - -	1
24	39880 F	Throat Plate Support, rear, for machines w/o "Air-Klipp" - - - - -	1
25	93 A	Screw, for rear throat plate support, for machines w/o "Air-Klipp" - - - - -	1
26	39843 F	Plate Washer, for main feed bar guide screw - - - - -	1
27	22541 B	Screw, for main feed bar guide - - - - -	2
28	376 A	Screw, for finger protector - - - - -	1
29	25 S	Screw, for finger protector plate - - - - -	2
30	21695 AB	Finger Protector Plate - - - - -	1
31	39843 G	Washer - - - - -	1
32	12934 A	Nut, for finger protector screw - - - - -	1
33	21695 AA	Finger Protector - - - - -	1
34	21695 AM	Felt Pad - - - - -	1
35	22541 B	Screw, for cast-off support plate - - - - -	2
36	8372 A	Washer, for cast-off support plate screw - - - - -	2
37	73 A	Screw, for looper thread take-up eyelet - - - - -	2
38	52958 D	Looper Thread Take-up Eyelet - - - - -	2
39	39868 J	Cast-off Wire - - - - -	1
40	77 A	Screw, for cast-off wire - - - - -	2

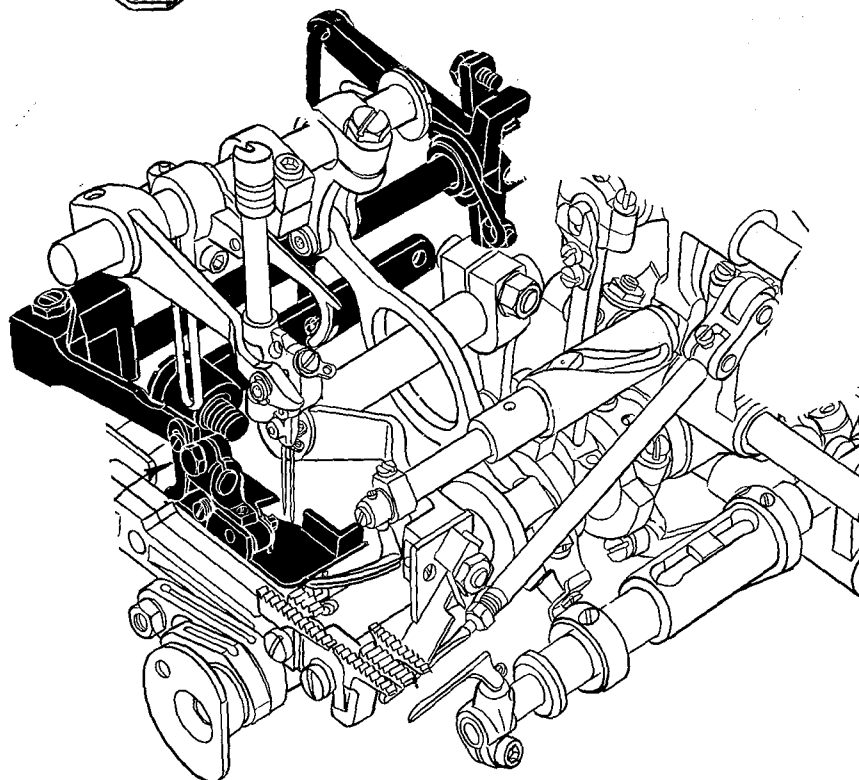
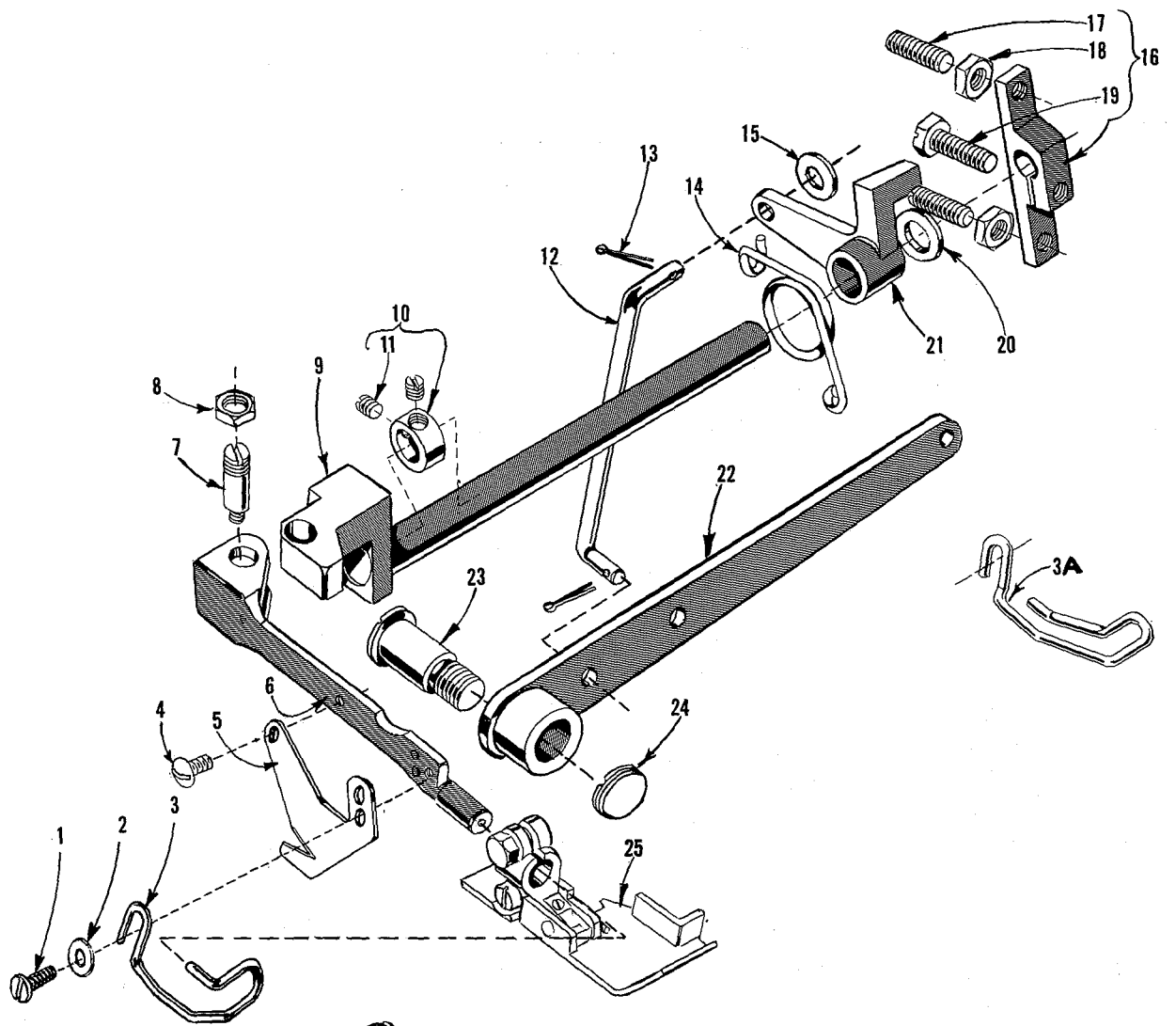



PRESSER ARM AND FOOT LIFTER PARTS

<u>Ref. No.</u>	<u>Part No.</u>	<u>Description</u>	<u>Amt. Req.</u>
1	22797 A	Screw, for chain cutting knife and finger guard - - - - -	1
2	53678 N	Washer - - - - -	1
3	99682 M	Finger Guard, for all Styles except 39800 CX, CY, VCX, and VCY - - - - -	1
3A	21695 AL	Finger Guard, for Styles 39800 CX, CY, VCX and VCY - - - - -	1
4	22547 A	Screw, for chain cutting knife - - - - -	1
5	39856 C	Chain Cutting Knife - - - - -	1
6	39656 B	Presser Arm, for No. 12 3/16 gauge, on Styles 39800 CA and CB - - - - -	1
-	39856 D	Presser Arm, for all Styles and gauges, except No. 12 3/16 gauge, on Styles 39800 CA and CB - - - - -	1
7	22791 H	Screw, for presser arm - - - - -	1
8	258 A	Nut, for presser arm screw - - - - -	1
9	39855 C	Foot Lifter Lever Shaft - - - - -	1
10	12865	Thrust Collar, for foot lifter lever shaft - - - - -	1
11	88	Screw, for thrust collar - - - - -	2
12	39857 H	Foot Lifter Lever Connecting Link - - - - -	1
13	660-142	Cotter Pin, for connecting link - - - - -	2
14	39855 A	Foot Lifter Lever Spring - - - - -	1
15	8372 A	Washer, for connecting link - - - - -	1
16	39555 C	Foot Lifter Lever Arm - - - - -	1
17	22597 E	Screw, for lever arm - - - - -	2
18	12538	Lock Nut, for lever arm screw- - - - -	2
19	627	Screw, for lever arm - - - - -	1
20	41332 J	Washer - - - - -	1
21	39855 B	Foot Lifter Intermediate Lever - - - - -	1
22	39855	Foot Lifter Lever - - - - -	1
23	22566 B	Screw, for foot lifter lever - - - - -	1
24	22571 D	Plug Screw, for foot lifter hole - - - - -	1
25		Presser Foot (See Pages 43 and 45)- - - - -	1

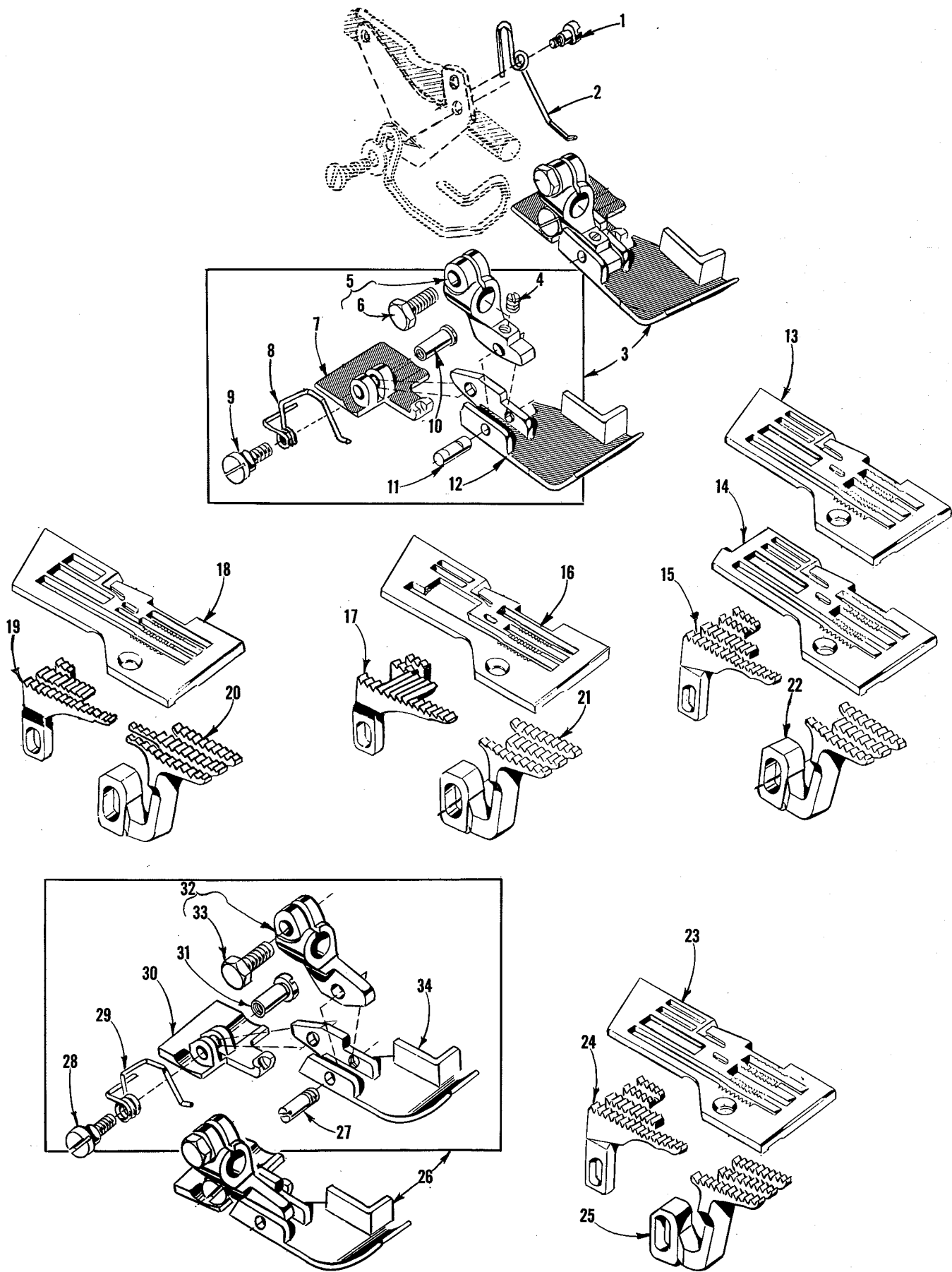

PRESSER FEET, FEED DOGS AND THROAT PLATES

				39800 CA, CB		39800 CP, CQ			39800 VCP, VCQ
				Gauge		Gauge			Gauge
				5 1/8	12 3/16	5 1/8	8 3/16	12 3/16	12 3/16
Ref. No.	Part No.	PRESSER FOOT							
3	39820 A-5 1/8			●		●			
26	39820 A-8 3/16					●			
3	39820 A-12 3/16				●		●	●	
DIFF. FEED DOG									
		Teeth per in.	I.D. Mark						
20	39626 D	16	"BR"	●		●			
21	39626 G	16	"BU"		●				
25	39826 B	16	"QG"			●			
22	39826 A	12	"FT"				●	●	
MAIN FEED DOG									
19	39805 G-5 1/8	16	"QC"	●		●			
17	39605 G-12 3/16	16	"DY-12"		●				
24	39805 A-8 3/16	16	"QE"			●			
15	39805 A-12 3/16	12	"FU"				●	●	
THROAT PLATE			I.D. MARK						
18	39824 G-5 1/8	"DH-5 1/8"		●		●			
16	39828 J-12 3/16	"DL"			●				
23	39828 A-8 3/16	"DP-8 3/16"				●			
13	39824 A-12 3/16	"CN-12 3/16"					●		
14	39824 B-12 3/16	"CX"						●	

PRESSER FEET - Component Parts

39810 A-12 3/16 & 39820 A-5 1/8

Ref. No.	Part No.	Description	I.D. Mark	Amt. Req.
*1	39830 AJ	Shoulder Screw, for No. 39830 AL		1
*2	39830 AL	Spring for presser foot bottom		1
4	22733	Set Screw, for presser foot bottom hinge pin		1
5	39830	Presser Foot Shank, for No. 12 3/16 gauge	"M"	1
	39830 G	Presser Foot Shank, for No. 5 1/8 gauge	"N"	1
6	22588 A	Clamp Screw		1
7	39830 A	Needle Hole Section, for No. 12 3/16 gauge	"BC"	1
	39830 H	Needle Hole Section, for No. 5 1/8 gauge	"BD"	1
8	39830 S	Spring, for needle hole section		1
9	39830 F	Hinge Screw, for needle hole section		1
10	39830 B	Locknut Screw, for No. 12 3/16 gauge needle hole section		1
	39830 J	Locknut Screw, for No. 5 1/8 gauge needle hole section		1
11	39830 E	Hinge Pin, for presser foot bottom		1
12	39830 C	Presser Foot Bottom, for No. 12 3/16 gauge	"BZ-12 3/16"	1
	39830 K	Presser Foot Bottom, for No. 5 1/8 gauge	"CC"	1
39820 A-8 3/16				
27	22799 AF	Hinge Screw, for presser foot bottom		1
28	39830 F	Hinge Screw, for needle hole section		1
29	39830 AB	Spring, for needle hole section		1
30	39830 Y	Needle Hole Section	"BG"	1
31	39830 J	Locknut Screw		1
32	39830 T	Presser Foot Shank	"R"	1
33	22588 A	Clamp Screw		1
34	39830 W	Presser Foot Bottom	"CP"	1

\*Not components of presser foot assembly

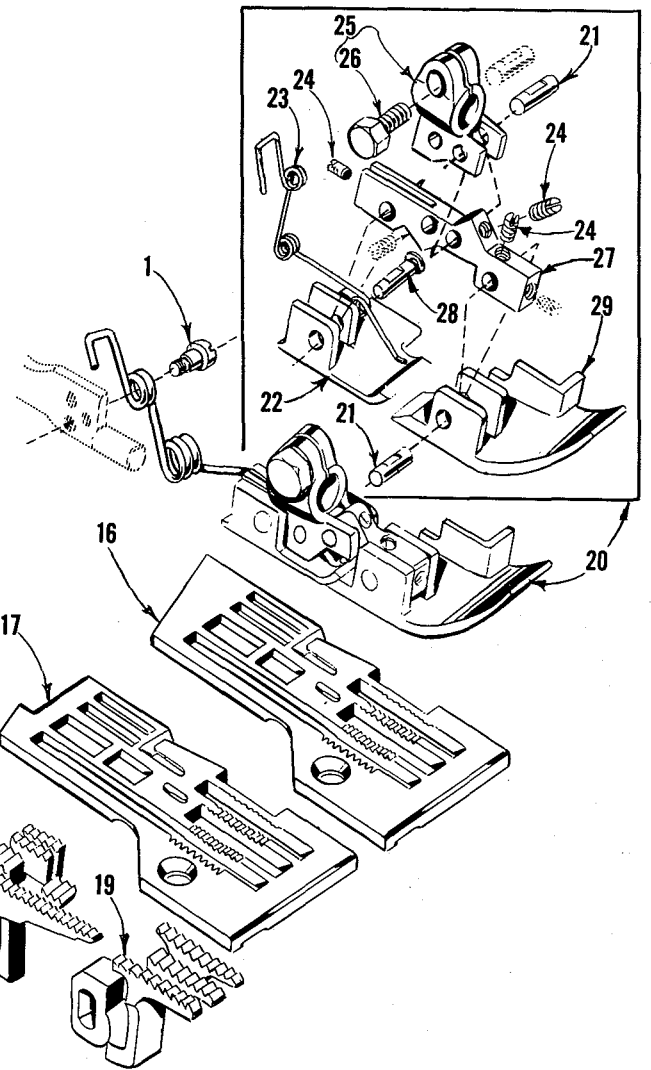
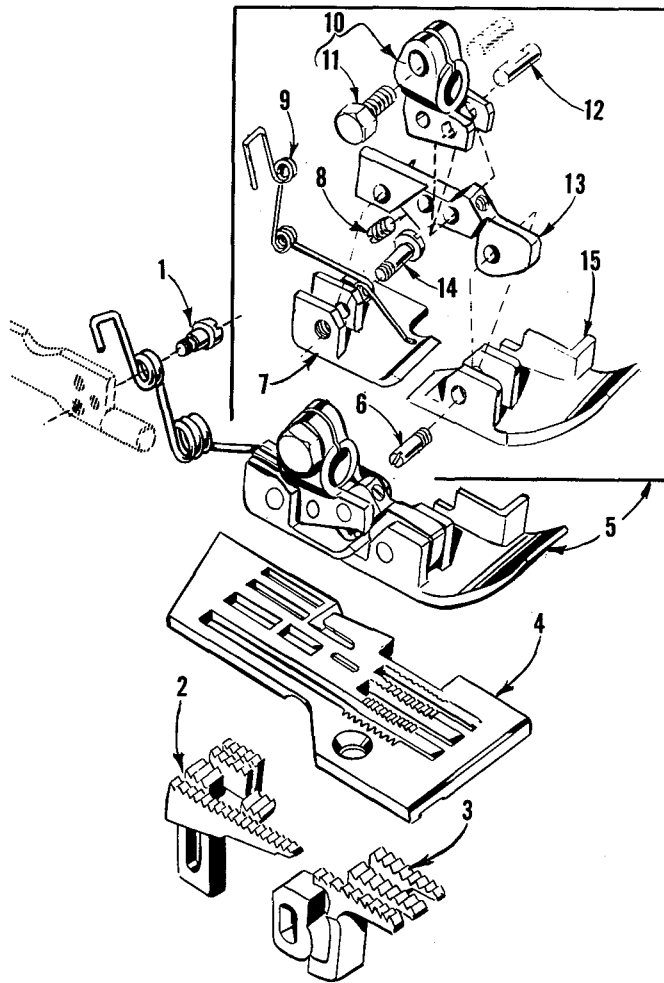

PRESSER FEET, FEED DOGS AND THROAT PLATES

				39800 CX, CY		39800 VCX,VCY
				Gauge		Gauge
				8 3/16	12 3/16	12 3/16
Ref. No.	Part No.	PRESSER FOOT				
5	39820 E-8 3/16			●		
20	39820 E-12 3/16				●	●
		DIFF. FEED DOG	Teeth per in.	I.D. Mark		
3	39826 B		16	"QG"	●	
19	39826 A		12	"FT"		●
		MAIN FEED DOG				
2	39805 E-8 3/16		16	"QF"	●	
18	39805 E-12 3/16		16	"PY"		●
		THROAT PLATE				
4	39828 E-8 3/16			"DR"	●	
16	39828 E-12 3/16			"EE"		●
17	39828 F-12 3/16			"ED"		●

PRESSER FEET - Component Parts

39820 E-8 3/16

Ref. No.	Part No.	Description	I.D. Mark	Amt. Req.
*1	39830 AJ	Shoulder Screw, for tractor foot		1
6	22799 AF	Hinge Screw, for presser foot bottom		1
7	39830 X	Needle Hole Section	"BF"	1
8	22733	Set Screw		1
9	39830 AH	Tractor Foot Spring		1
10	39830 U	Presser Foot Shank	"S"	1
11	22588 A	Clamp Screw		1
12	39830 AT	Hinge Pin		1
13	39830 Z	Presser Foot Yoke		1
14	39830 AA	Hinge Screw		1
15	39830 V	Presser Foot Bottom	"CE"	1

39820 E-12 3/16

*1	39830 AJ	Shoulder Screw, for tractor foot		1
21	39830 AT	Hinge Pin		2
22	39830 N	Needle Hole Section	"BE"	1
23	39830 AH	Tractor Foot Spring		1
24	22733	Set Screw		3
25	39830 M	Presser Foot Shank	"p"	1
26	22588 A	Clamp Screw		1
27	39830 R	Presser Foot Yoke		1
28	39830 AK	Hinge Pin		1
29	39830 P	Presser Foot Bottom	"CD"	1

\* Not a component of presser foot assembly

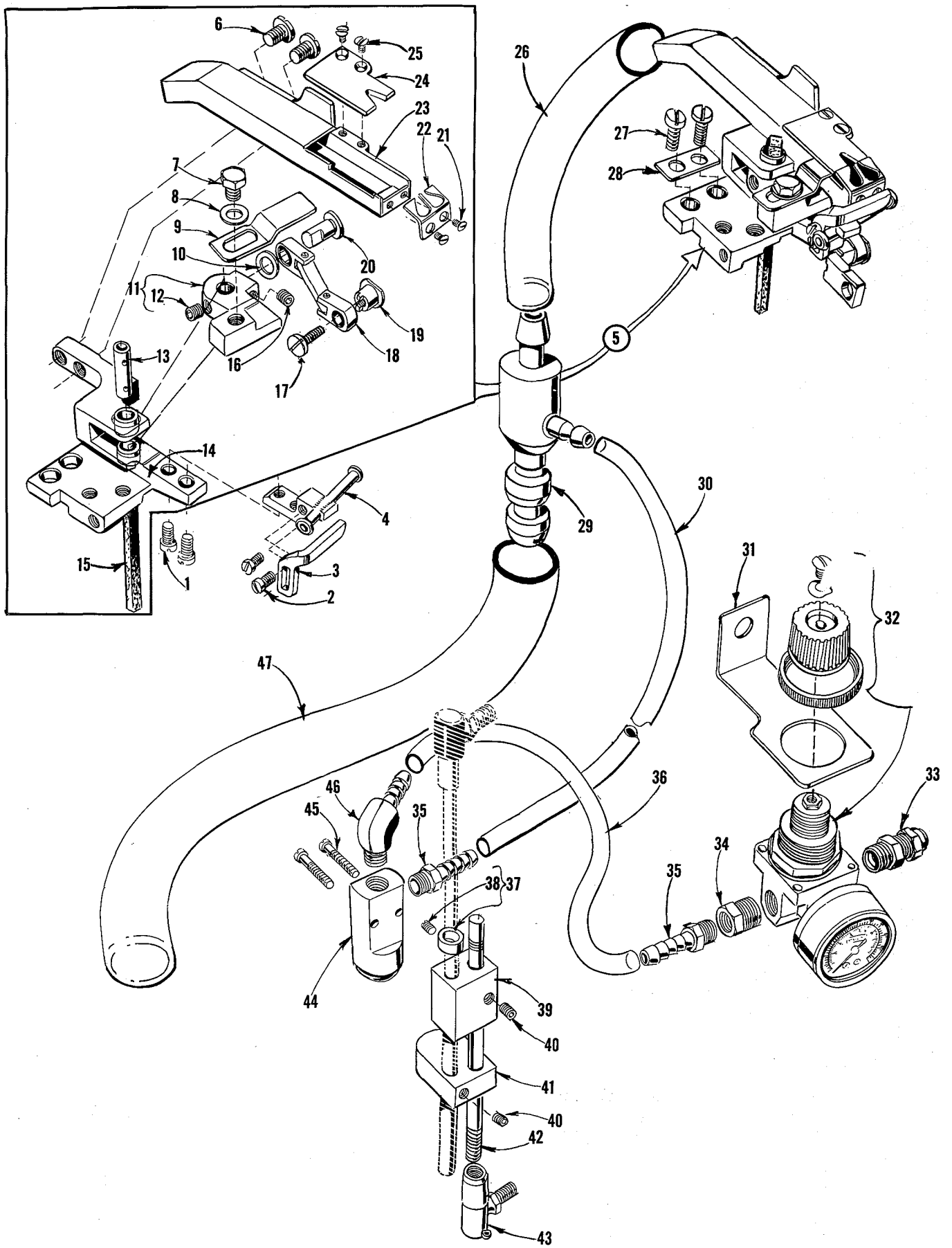

"AIR-KLIPP" CHAIN CUTTER AND PNEUMATIC PARTS  
(For Styles 39800 VCP, VCQ, VCX, VCY)

<u>Ref. No.</u>	<u>Part No.</u>	<u>Description</u>	<u>Amt. Req.</u>
1	22562 A	Screw - - - - -	2
2	77	Screw - - - - -	2
3	39880 K	Throat Plate Support, rear - - - - -	1
4	39880 G	Throat Plate Support Bracket, rear - - - - -	1
5	G29911 Q	Air-Klipp Assembly - - - - -	1
6	22829	Screw - - - - -	2
7	22519	Screw - - - - -	1
8	53634 C	Washer - - - - -	1
9	99669 A	Movable Knife - - - - -	1
10	95910	Washer - - - - -	1
11	99667 B	Knife Lever - - - - -	1
12	22894 W	Set Screw - - - - -	1
13	99674 B	Stud - - - - -	1
14	99663 F	Base - - - - -	1
15	15430 L	Oil Wick - - - - -	1
16	22894 W	Set Screw - - - - -	1
17	G22797 A	Screw - - - - -	1
18	99672	Knife Driving Link - - - - -	1
19	99673	Link Bushing - - - - -	1
20	99671	Stud, for link - - - - -	1
21	22716 A	Screw - - - - -	2
22	99677 B	Inlet Part, marked "GC", for No. 8 3/16 and 12 3/16 gauge machines - - - - -	1
-	99677 F	Inlet Part, marked "GG", for No. 5 1/8 gauge machines - - - - -	1
23	99676 K	Air-Klipp Tube, complete - - - - -	1
24	99670 C	Upper Knife - - - - -	1
25	22716	Screw - - - - -	2
26	671 B-12	Air Tube, 12 inches (304.80 mm) long - - - - -	1
27	22541 B	Screw - - - - -	2
28	39843 F	Washer Plate - - - - -	1
29	671 D-2	Air Jet - - - - -	1
30	671 B-3	Air Tube, 45 inches (1143.0 mm) long - - - - -	1
31	39583 A	Mounting Bracket - - - - -	1
32	671 D-7	Pressure Regulator And Gauge - - - - -	1
33	671 F-8	Straight Fitting - - - - -	1
34	671 F-6	Reducer Bushing - - - - -	1
35	671 F-1	Male Fitting - - - - -	2
36	671 B-1	Air Tube, 36 inches (914.40 mm) long - - - - -	1
37	61242	Pitman Rod Collar - - - - -	1
38	88	Screw - - - - -	2
39	671-2	Air Valve Mounting Block - - - - -	1
40	22651 CB-4	Set Screw - - - - -	2
41	671-3	Air Valve Actuator Block - - - - -	1
42	1453 A	Pitman Rod - - - - -	1
43	21371 MZ	Connection - - - - -	1
44	671-1	Air Valve - - - - -	1
45	22729 B	Screw - - - - -	2
46	671 F-2	Elbow Fitting - - - - -	1
47	671 B-11	Air Tube, 30 inches (762.0 mm) long - - - - -	1
	670 E-2	Cable Tie (not shown) - - - - -	3

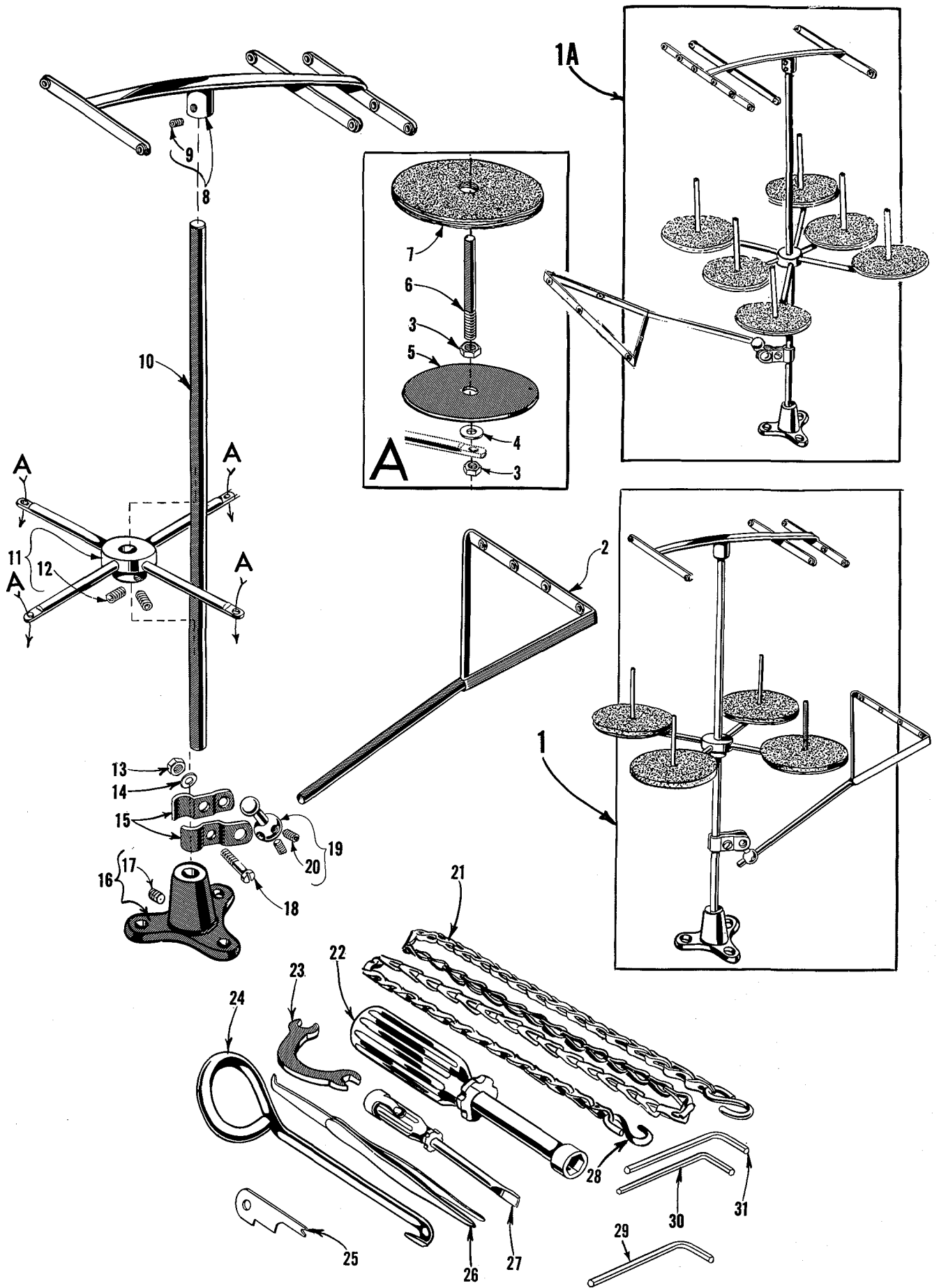



THREAD STAND AND ACCESSORIES

Ref. No.	Part No.	Description	Amt. Req.
1	21101 H-4	Thread Stand, complete, for 4 cones, for Styles 39800 CA, CP, CX, VCP and VCX - - - - -	1
+ 1A		Thread Stand, complete, for 6 cones, for Styles 39800 CB, CQ, CY, VCQ and VCY - - - - -	1
2	21114 S-4	Lead Eyelet, for No. 21101 H-4 - - - - -	1
-	21114 AL-5	Lead Eyelet, for 5 threads - - - - -	1
3	258 A	Nut - - - - -	8 or 10
4	652-16	Washer - - - - -	4 or 5
5	21114	Spool Seat Disc - - - - -	4 or 5
6	21114 W	Spool Pin - - - - -	4 or 5
7	21104 V	Pad, for thread cones - - - - -	4 or 5
8	21114 H-4	Eyelet Support, for No. 21101 H-4 - - - - -	1
-	21114 H-6	Eyelet Support, for 6 threads - - - - -	1
9	22651 CD-4	Screw - - - - -	1
10	21104 B-24	Thread Stand Rod - - - - -	1
11	21114 D-4	Spool Seat Support, for No. 21101 H-4 - - - - -	1
-	21114 D-6	Spool Seat Support, for 6 threads - - - - -	1
12	22651 CD-5	Screw - - - - -	2
13	21104 H	Nut - - - - -	1
14	652-16	Washer - - - - -	1
15	21114 U	Lead Eyelet Ball Split Socket - - - - -	2
16	21114 A	Thread Stand Base - - - - -	1
17	22651 CD-4	Screw - - - - -	1
18	22810	Clamp Screw - - - - -	1
19	21114 T	Lead Eyelet Socket Ball - - - - -	1
20	22651 CD-4	Screw - - - - -	2
21	421 D-34	Foot Lifter Treadle Chain, 34 inches (863.60 mm) long - - - - -	1
22	21388 AU	Socket Wrench, for 3/8 inch (9.52 mm) hexagonal nut holding feed eccentric - - - - -	1
23	21388 W	Wrench, curved double end, 9/32 inch (7.14 mm) opening - - - - -	1
24	21227 BF	Feed Eccentric Extractor Hook - - - - -	1
*25	21225-3/32	Looper Gauge, 3/32 inch (2.38 mm) - - - - -	1
26	660-272	Thread Tweezers - - - - -	1
27	21207 B	Screwdriver, 1/8 inch (3.18 mm) diameter - - - - -	1
28	660-264	"S" Hook for treadle chain - - - - -	2
29	WR56	Wrench, 1/8 inch (3.18 mm) hexagonal - - - - -	1
30	WR65	Wrench, 1/16 inch (1.59 mm) hexagonal - - - - -	1
31	WR69	Wrench, 9/64 inch (3.58 mm) hexagonal - - - - -	1
-	660-458	Dust Cover (not shown) - - - - -	1
-	39899 A	Threading Wire (not shown) - - - - -	1
-	SC-303	Wood Screw, #12 x 1 inch (25.4 mm) long (not shown) - - - - -	3
-	28604 R	Container of Oil, 16 ounces, Spec. 175 (not shown) - - - - -	1
-	652-24	Washer, for use in tableboard (not shown) - - - - -	8
*	39803	Edge Guide, cloth plate mounted (not shown) - - - - -	1
*	29481 J	Edge Guide (not shown) - - - - -	1
*	21227 DD	Needle Height Gauge (not shown) - - - - -	1
*	21394 N	Knife Grinder (not shown) - - - - -	1
*	39598 G	Swinging Frame - required with No. 21394 N (not shown) - - - - -	1

\* Available as extra send and charge item.

+ Number for complete thread stand not available, order component parts.

NUMERICAL INDEX OF PARTS

Part No.	Page No.	Part No.	Page No.	Part No.	Page No.
WO-3 . . . . .	29, 35	15430 L . . . . .	47	22769 B . . . . .	27
CL21 . . . . .	29, 37	21101 H-4 . . . . .	49	22775 . . . . .	33
22 KH . . . . .	35	21104 B-24 . . . . .	49	22781 . . . . .	33
HS24 C . . . . .	37	21104 H . . . . .	49	22784 L . . . . .	29
25 S . . . . .	39	21104 V . . . . .	49	22791 H . . . . .	41
28 C . . . . .	29	21114 . . . . .	49	22797 A . . . . .	41
30-106 Blk. . . . .	27	21114 A . . . . .	49	G22797 A . . . . .	47
40-139 . . . . .	29	21114 D-4 . . . . .	49	22799 AF . . . . .	43, 45
51-238 Blk. . . . .	27	21114 D-6 . . . . .	49	22806 A . . . . .	25
WR56 . . . . .	49	21114 H-4 . . . . .	49	22810 . . . . .	49
WR65 . . . . .	49	21114 H-6 . . . . .	49	22824 B . . . . .	25
CO67 E . . . . .	27	21114 S-4 . . . . .	49	22829 . . . . .	47
WR69 . . . . .	49	21114 T . . . . .	49	22852 C . . . . .	29
73 A . . . . .	39	21114 U . . . . .	49	22892 B . . . . .	35
77 . . . . .	27, 31, 47	21114 W . . . . .	49	22894 C . . . . .	29, 31, 33, 35
77 A . . . . .	39	21114 AL-5 . . . . .	49	22894 D . . . . .	27
87 U . . . . .	29, 35	21207 B . . . . .	49	22894 J . . . . .	27, 31, 35
88 . . . . .	25, 41, 47	21225-3/32 . . . . .	49	22894 L . . . . .	29, 35
88 F . . . . .	35	21227 BF . . . . .	49	22894 U . . . . .	27
90 . . . . .	25, 35	21227 DD . . . . .	49	22894 W . . . . .	47
93 . . . . .	27	21371 MZ . . . . .	47	22894 AE . . . . .	31, 33
93 A . . . . .	27, 39	21388 W . . . . .	49	22894 AF . . . . .	33
95 . . . . .	27, 37	21388 AU . . . . .	49	22894 AG . . . . .	25
97 . . . . .	35	21394 N . . . . .	49	28604 R . . . . .	49
97 A . . . . .	27	21695 AA . . . . .	39	29477 MA . . . . .	37
98 . . . . .	33	21695 AB . . . . .	39	29477 MB . . . . .	27
109 . . . . .	39	21695 AL . . . . .	41	29477 MF . . . . .	27
120 GS . . . . .	29	21695 AM . . . . .	39	29481 J . . . . .	49
120 GAS . . . . .	29	22503 F . . . . .	33, 35	G29911 Q . . . . .	47
138 . . . . .	25	22519 . . . . .	47	39151 . . . . .	31
258 . . . . .	27	22524 . . . . .	35	39158 U . . . . .	39
258 A . . . . .	41, 49	22541 B . . . . .	25, 39, 47	39501 K . . . . .	25
SC303 . . . . .	49	22541 D . . . . .	37	39501 DN . . . . .	25
376 A . . . . .	37, 39	22547 A . . . . .	41	39501 DU . . . . .	25
421 D-34 . . . . .	49	22548 . . . . .	37	39516-625 . . . . .	27
482 C . . . . .	31, 33, 35	22562 A . . . . .	33, 35, 47	39516-626 . . . . .	27
538 . . . . .	31, 33	22564 D . . . . .	29	39516-627 . . . . .	27
605 . . . . .	29	22564 G . . . . .	35	39521 G . . . . .	27
627 . . . . .	41	22564 J . . . . .	37	39534 . . . . .	27
652-16 . . . . .	49	22565 . . . . .	37	39534 G . . . . .	27
652-24 . . . . .	49	22565 C . . . . .	33	39535 J . . . . .	27
660-142 . . . . .	41	22565 R . . . . .	35	39536 B . . . . .	27
660-206 . . . . .	31, 33, 35	22566 B . . . . .	41	39536 C . . . . .	27
660-210 . . . . .	39	22569 . . . . .	25	39536 E . . . . .	27, 33
660-220 . . . . .	29	22569 B . . . . .	27, 37	39536 AE . . . . .	27
660-243 . . . . .	39	22569 C . . . . .	25, 37	39536 AF . . . . .	27
660-264 . . . . .	49	22569 D . . . . .	25, 37, 39	39540 B-8 . . . . .	27
660-268 . . . . .	27	22569 G . . . . .	25	39540 B-10 . . . . .	27
660-272 . . . . .	49	22569 K . . . . .	39	39541 A . . . . .	27
660-416 . . . . .	29	22571 D . . . . .	41	39543 . . . . .	35
660-442 . . . . .	29	22571 E . . . . .	39	39543 A . . . . .	35
660-443 . . . . .	27	22572 B . . . . .	29	39543 E . . . . .	33, 35
660-458 . . . . .	49	22585 . . . . .	39	39543 M . . . . .	33, 35
660-469 . . . . .	37	22585 A . . . . .	35	39543 P . . . . .	33, 35
660-506 . . . . .	25	22585 C . . . . .	39	39543 S . . . . .	35
666-255 . . . . .	31, 35	22585 R . . . . .	37	39543 T . . . . .	35
666-268 . . . . .	25	22586 R . . . . .	25	39543 W . . . . .	35
666-271 . . . . .	25	22587 E . . . . .	33	39544 B . . . . .	31
666-280 . . . . .	25	22587 M . . . . .	27	39544 D . . . . .	31
666-290 . . . . .	25	22588 A . . . . .	29, 43, 45	39544 J . . . . .	35
670 E-2 . . . . .	47	22588 J . . . . .	35	39544 L . . . . .	25
671-1 . . . . .	47	22591 . . . . .	37	39550 C . . . . .	35
671-2 . . . . .	47	22597 E . . . . .	41	39550 E . . . . .	35
671-3 . . . . .	47	22650 AE-4 . . . . .	25	39550 M . . . . .	35
671 B-1 . . . . .	47	22651 CB-4 . . . . .	47	39550 Z . . . . .	35
671 B-3 . . . . .	47	22651 CD-4 . . . . .	49	39555 C . . . . .	41
671 B-11 . . . . .	47	22651 CD-5 . . . . .	49	39557 B . . . . .	37
671 B-12 . . . . .	47	22652 A-6 . . . . .	33	39568 E . . . . .	37
671 D-2 . . . . .	47	22652 B-10 . . . . .	29	39568 J . . . . .	37
671 D-7 . . . . .	47	22653 B-12 . . . . .	35	39568 L . . . . .	37
671 F-1 . . . . .	47	22653 D-4 . . . . .	25	39568 P . . . . .	37
671 F-2 . . . . .	47	22657 D-12 . . . . .	25	39571 B . . . . .	33
671 F-6 . . . . .	47	22704 . . . . .	37	39571 C . . . . .	33
671 F-8 . . . . .	47	22716 . . . . .	47	39572 A . . . . .	33
1025 L . . . . .	35	22716 A . . . . .	47	39573 A . . . . .	29, 33
1453 A . . . . .	47	22729 B . . . . .	35, 47	39573 E . . . . .	33
6042 A . . . . .	33	22729 D . . . . .	31, 33, 35	39573 K . . . . .	25
8372 A . . . . .	25, 37, 39, 41	22729 E . . . . .	31, 33	39573 AA . . . . .	25
9937 . . . . .	33	22729 M . . . . .	33	39578 F . . . . .	25
12538 . . . . .	41	22733 . . . . .	29, 43, 45	39580 F . . . . .	35
12865 . . . . .	41	22738 . . . . .	33	39582 F . . . . .	25
12934 A . . . . .	39	22738 B . . . . .	29	39582 BK . . . . .	25
12982 . . . . .	31, 35	22743 . . . . .	37	39582 BL . . . . .	25
14077 . . . . .	35	22747 B . . . . .	27	39582 BM . . . . .	25
		22768 B . . . . .	35		

NUMERICAL INDEX OF PARTS

Part No.	Page No.	Part No.	Page No.	Part No.	Page No.
39582 BV	.25	39828 E-12 3/16	.45	39860	.35
39583 A	.47	39828 F-12 3/16	.45	39863	.29
39590	.25	39828 J-12 3/16	.43	39863 C	.29
39590 G	.27	39830	.43	39863 D	.29
39590 H	.27	39830 A	.43	39863 J	.29
39590 J	.27	39830 B	.43	39863 K	.37
39590 R	.27	39830 C	.43	39863 L	.37
39590 S	.27	39830 E	.43	39863 M	.37
39590 T	.25	39830 F	.43	39863 N	.37
39591 H	.27	39830 G	.43	39868 B	.39
39591 K	.27	39830 H	.43	39868 D	.37
39591 L	.27	39830 J	.43	39868 H	.37
39592 Y	.37	39830 K	.43	39868 J	.39
39592 Z	.37	39830 M	.45	39868 M	.39
39592 AA	.37	39830 N	.45	39868 N	.37
39592 AC	.37	39830 P	.45	39868 R	.27
39592 AD	.37	39830 R	.45	39868 X	.37
39592 AF	.37	39830 S	.43	39868 Y	.37
39592 AH	.37	39830 T	.43	39868 Z	.37
39592 AK	.37	39830 U	.45	39870	.33
39592 AL	.37	39830 V	.45	39871	.33
39592 AN	.37	39830 W	.43	39873	.33
39592 AR-2	.37	39830 X	.45	39873 B	.33
39592 AR-4	.37	39830 Y	.43	39878 C	.39
39592 AR-5	.37	39830 Z	.45	39878 E	.39
39593 C	.25	39830 AA	.45	39878 F	.39
39593 D	.25	39830 AB	.43	39878 G	.39
39593 J	.25, 27	39830 AH	.45	39880	.35
39593 K	.25	39830 AJ	.43, 45	39880 F	.39
39593 L	.25	39830 AK	.45	39880 G	.47
39594 N	.29, 35	39830 AL	.43	39880 H	.35
39595	.25	39830 AT	.45	39880 K	.47
39598 G	.49	39832	.25	39882	.25
39605 G-12 3/16	.43	39834 B	.25	39882 E	.25
39625 D	.35	39835 A	.27	39882 F	.25
39626 D	.43	39835 B	.27	39882 G	.25
39626 G	.43	39835 C	.27	39882 J	.25
39644	.33	39835 D	.39	39883	.35
39644 A	.33	39838	.27	39890 C	.27
39644 C	.25	39843	.35	39890 E	.27
39644 F	.31	39843 A	.35	39892 A-5	.37
39644 K	.33	39843 B	.35	39892 B	.37
39644 L	.33	39843 C	.35	39892 C	.37
39644 M	.33	39843 D	.29	39893	.39
39644 N	.33	39843 E	.35	39893 C	.25
39644 P	.33	39843 F	.39, 47	39894 A	.25
39644 R-2	.31, 33	39843 G	.39	39894 B	.25
39644 R-5	.31, 33	39843 H	.35	39894 C	.31
39644 S	.25	39844	.31	39899 A	.49
39644 U	.33	39844 A	.33	41071 G	.35
39644 V	.33	39844 B	.31	41332 J	.41
39644 W	.33	39844 C	.33	41336 C	.33
39644 X	.31, 33	39844 D	.33	43443 Q	.39
39650	.35	39849	.35	51236 A	.29
39650 A	.35	39852	.29	51257 H	.37
39656 B	.41	39852 A	.27	51292 A	.39
39673	.33	39852 C	.29	51292 C	.39
39690 A	.27	39852 D	.29	51292 D	.39
39691	.27	39852 E	.29	51292 F-2	.39
39803	.49	39852 F-5	.29	51292 G	.39
39805 A-8 3/16	.43	39852 F-8	.29	51295 B	.25
39805 A-12 3/16	.43	39852 F-12	.29	52344	.31
39805 E-8 3/16	.45	39852 J	.29	52958 D	.39
39805 E-12 3/16	.45	39852 K-5	.29	53634 C	.37, 47
39805 G-5 1/8	.43	39852 K-8	.29	53678 N	.41
39808	.33	39852 K-12	.29	55235 D	.33
39808 A	.35	39852 M	.25	55235 E	.33
39808 C	.35	39852 N	.29	56393 G	.25
39808 D	.31	39855	.41	56393 V	.25
39820 A-5 1/8	.43	39855 A	.41	61242	.47
39820 A-8 3/16	.43	39855 B	.41	95910	.47
39820 A-12 3/16	.43	39855 C	.41	99663 F	.47
39820 E-8 3/16	.45	39855 D	.25	99667 B	.47
39820 E-12 3/16	.45	39856	.37	99669 A	.47
39821	.27	39856 B	.41	99670 C	.47
39824 A-12 3/16	.43	39856 C	.41	99671	.47
39824 B-12 3/16	.43	39856 D	.41	99672	.47
39824 G-5 1/8	.43	39857 A	.37	99673	.47
39825	.35	39857 C	.37	99674 B	.47
39825 B	.35	39857 E	.37	99676 K	.47
39825 C	.35	39857 H	.41	99677 B	.47
39826 A	.43, 45	39857 J	.37	99677 F	.47
39826 B	.43, 45	39857 L	.37	99682 M	.41
39828 A-8 3/16	.43	39857 M	.37		
39828 E-8 3/16	.45	39857 N	.37		
		39857 P	.37		

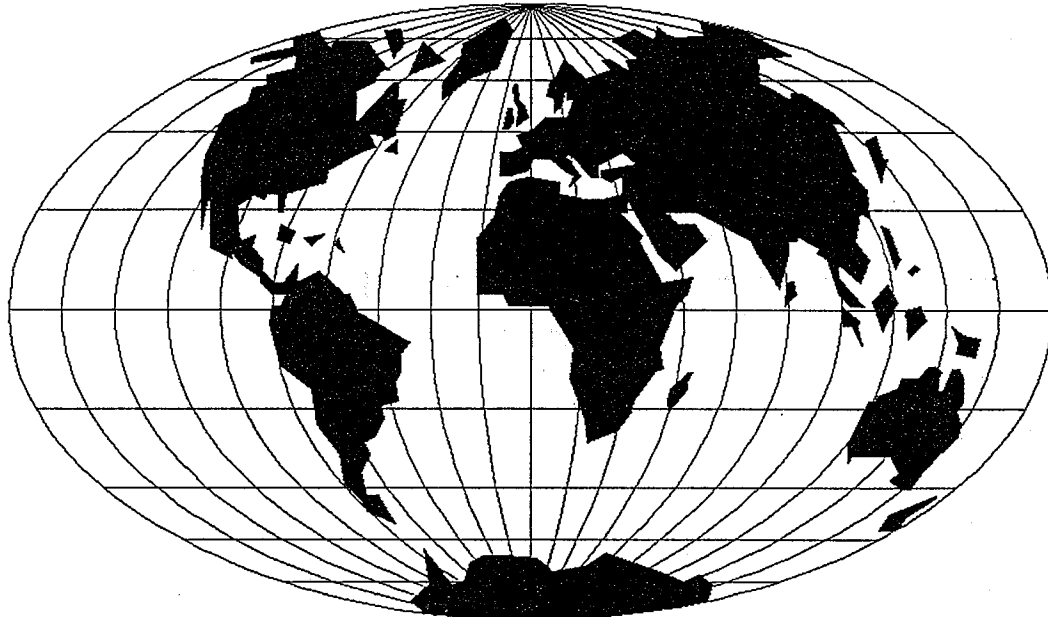

## WORLDWIDE SALES AND SERVICE

Union Special Corporation maintains sales and service facilities throughout the world. These offices will aid you in the selection of the right sewing equipment for your particular operation. Union Special Corporation representatives and service technicians are factory trained and are able to serve your needs promptly and efficiently. Whatever your location, there is a qualified representative to serve you.

---

**Corporate Offices:**

One Union Special Plaza  
Huntley, IL 60142  
(708) 669-5101

Union Special GmbH  
Raiffeisenstrasse 3  
D-71696 Möglingen, Germany  
Tel. 07141-2470

Brussels, Belgium  
Commerce, CA  
Leicester, England  
Lille, France  
Miami, FL  
Möglingen, Germany  
Huntley, IL  
Milan, Italy  
Osaka, Japan  
Hong Kong  
Charlotte, N.C.  
Montreal, Quebec  
El Paso, TX  
Mission, TX

Other Representatives throughout  
all parts of the world.



*Union Special*  
INDUSTRIAL SEWING EQUIPMENT